



Conceptual design of the neutron line and shutter between the Test Cell and the Facilities for Complementary Experiments.

1st DONES Users Workshop | 27 Sept 2022

A. Talarowska, R. Prokopowicz, G. Galązka, A. Serikov, B. Bieńkowska,
K. Tymińska, G. Wojtania



This work has been carried out within the framework of the EUROfusion Consortium and has received funding from the European Union's Horizon 2020 research and innovation programme under grant agreement number 633053. The views and opinions expressed herein do not necessarily reflect those of the European Commission.

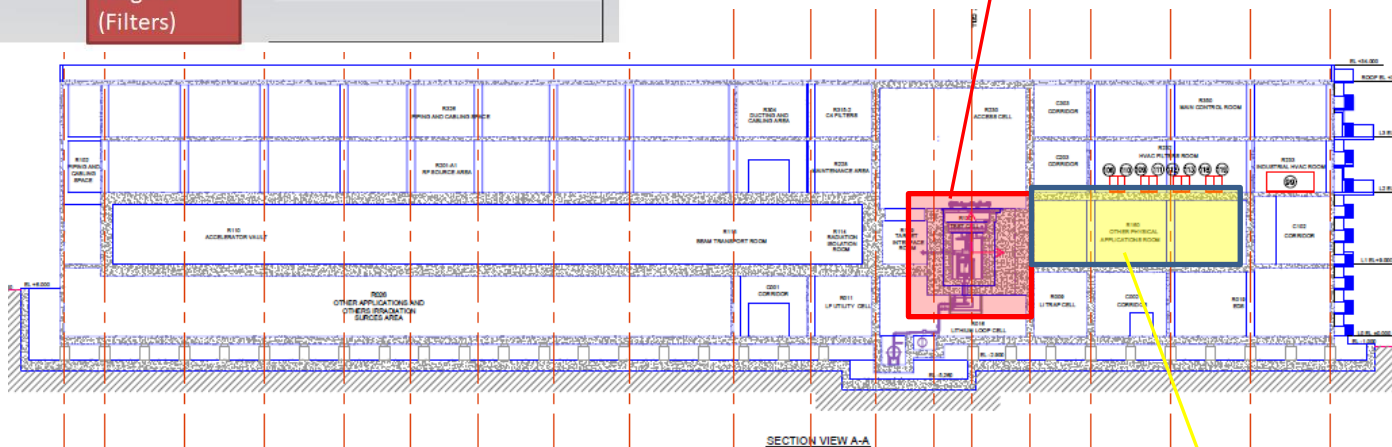
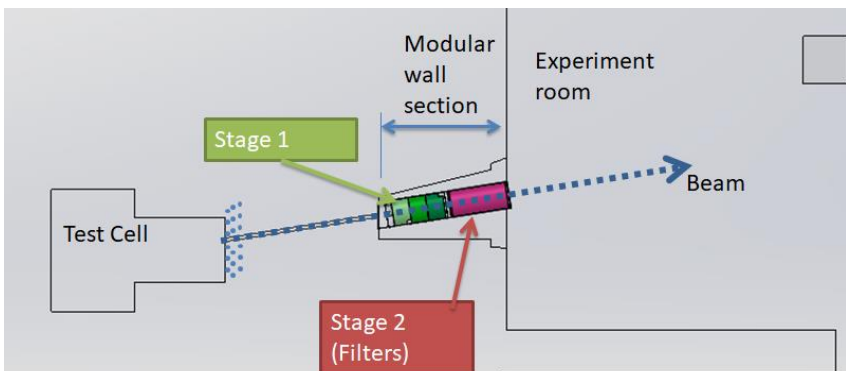

- Way of transport neutrons from TC to R160
- Radiation protection working areas classification under irradiation criteria can be found in Preliminary Safety Analysis Report. R160 is marked Red (Forbidden) with the neutron line open. When it is closed, we aim for Yellow (Limited permanence, dose < 1 mSv/h).

Complementary Experiments Room (R160)
26 m x 11 m x 8 m
(L x W x H)

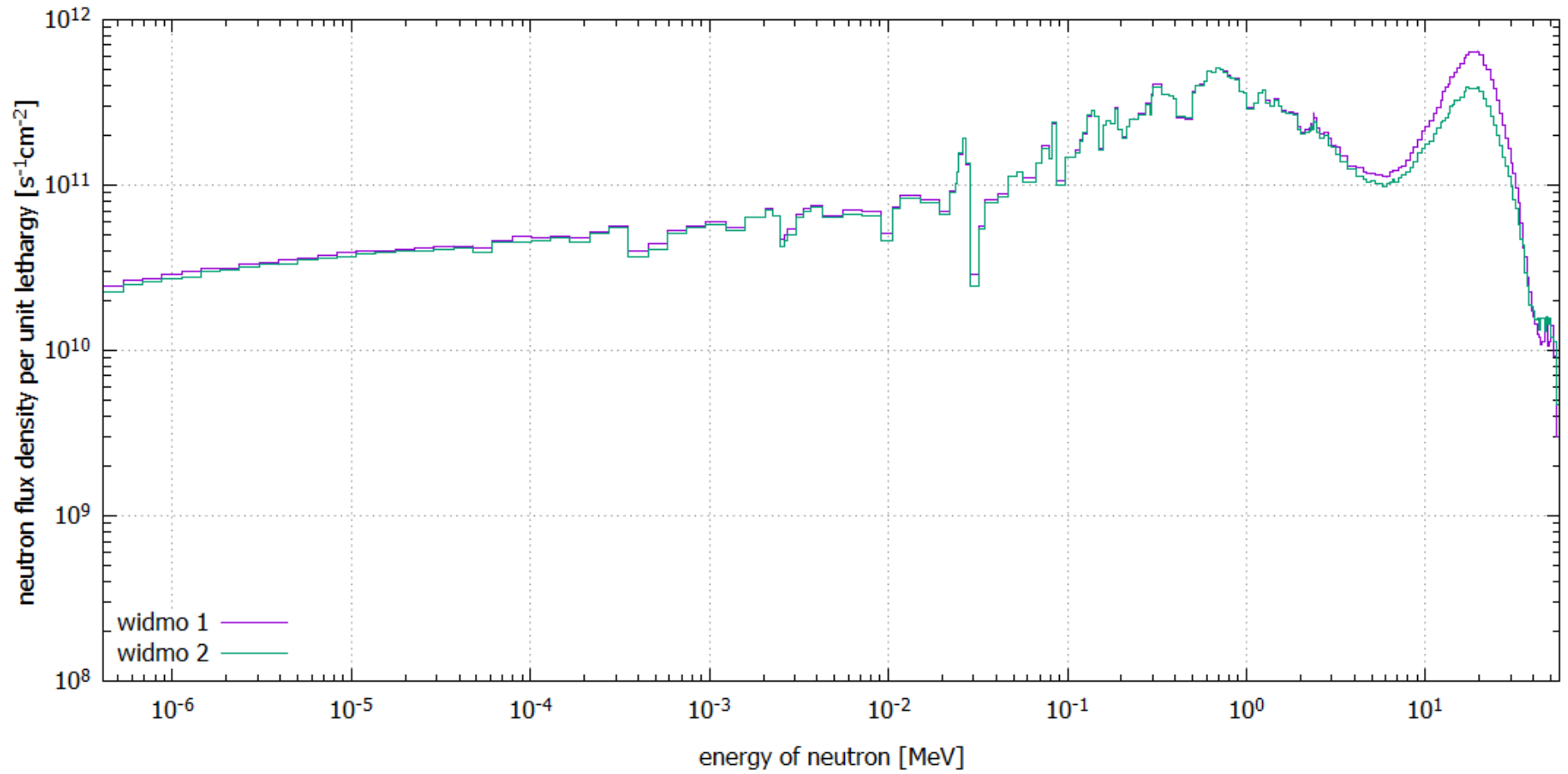

- Mostly fast neutrons up to 40 MeV

Main dimensions of the Neutron Shutter

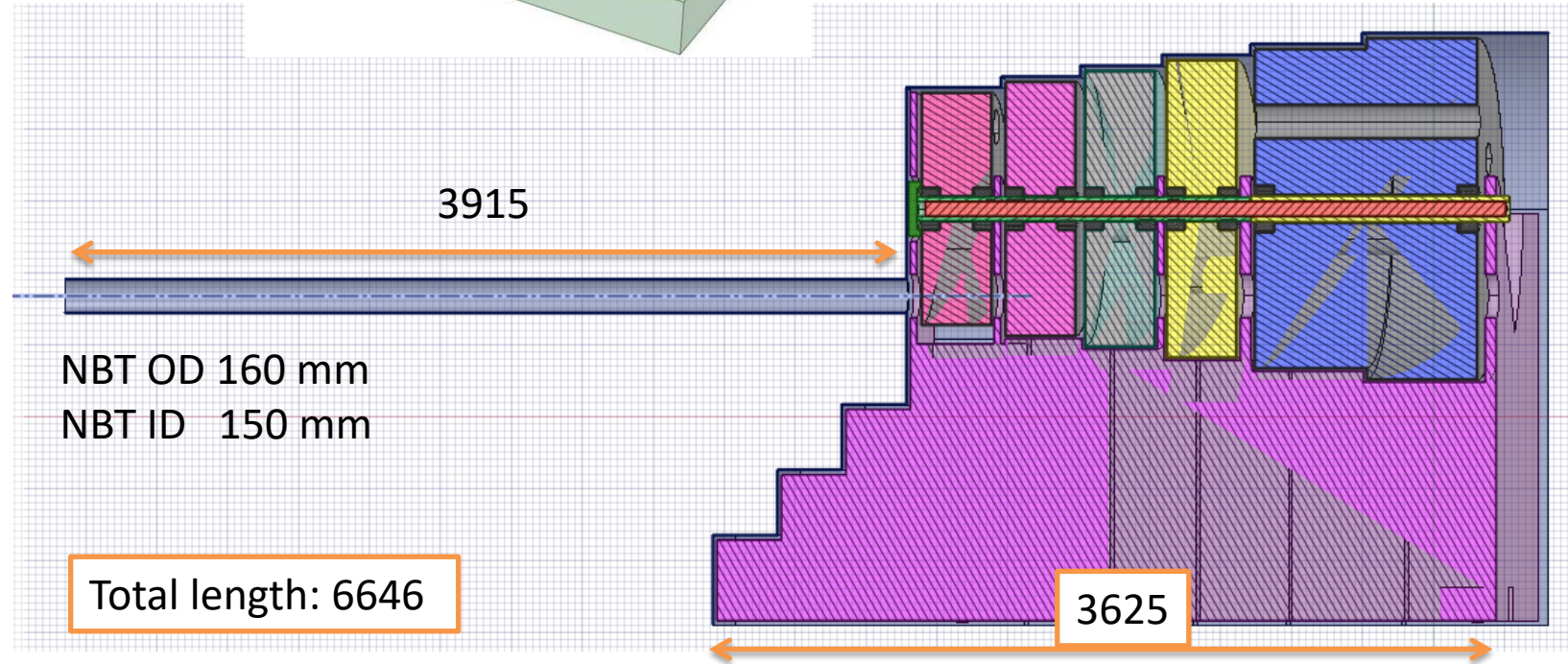
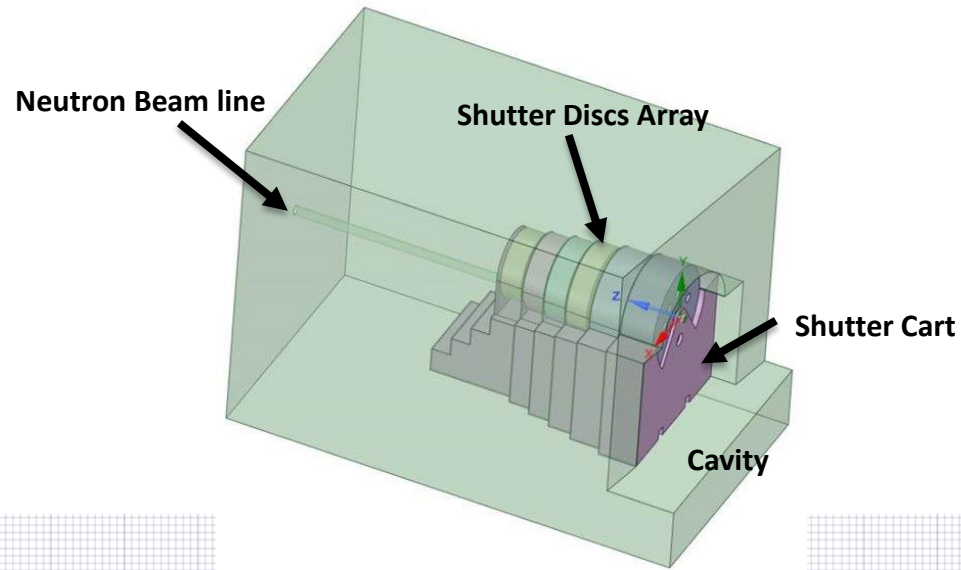

- **Beam diameter: 150mm**
- **NBT main parameters:**
 - Beam Channel I.D.: 150mm
 - Channel Wall Thickness : 5mm
 - Concrete Wall I.D.: 200mm.
- Shutter Thickness : 2590mm
- **Filter Disc: 1040mm**
- Cart length: 3625mm
- Maximal Width: 2510mm
- Clearances: 10-20mm

- **Thermal neutron flux at the outlet of the neutron shutter**
 10^7 - 10^8 neutrons/(cm²·s)

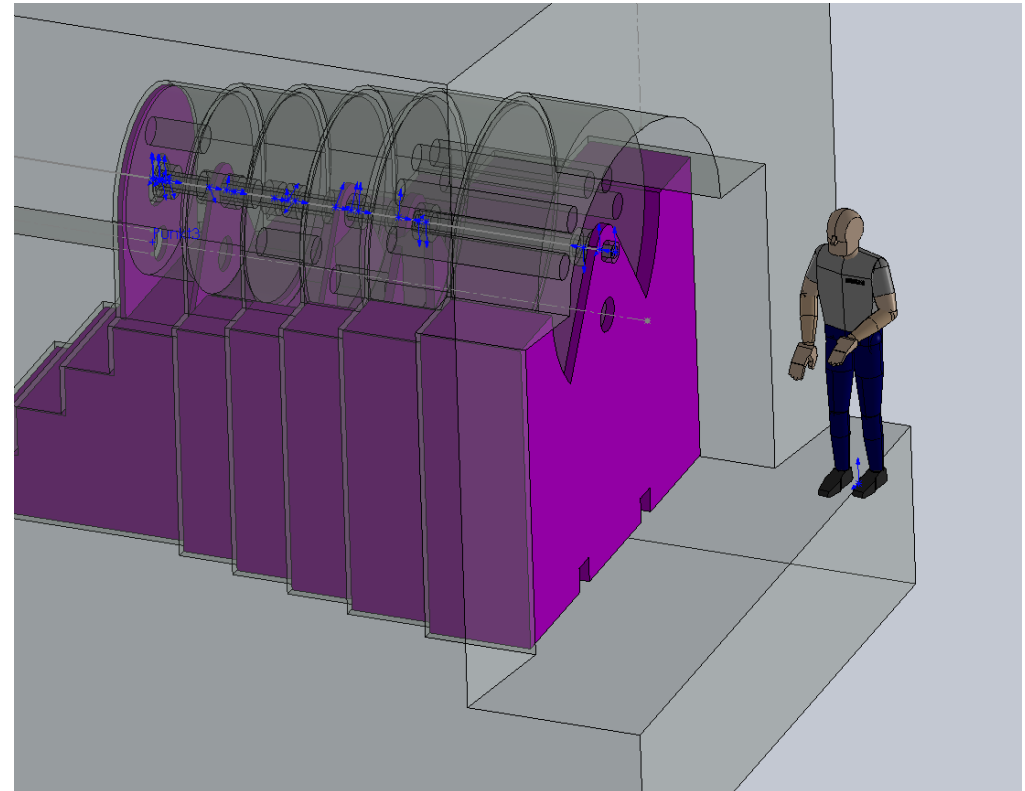

IRRADIATION AREA CLASSIFICATION

| Area | Colour | Total dose rate Effective dose rate external & internal exposure |
|---------------------------------------|---------------------|--|
| Unrestricted area within the facility | | |
| Unrestricted area | White | < 0.5 μ Sv/h |
| Controlled and Supervised areas | | |
| Supervised area | Blue | < 3 μ Sv/h |
| Controlled area | Free Permanenced | < 10 μ Sv/h |
| | Limited Regulated | < 1 mSv/h |
| | Specially Regulated | < 100 mSv/h |
| | Forbidden | \geq 100 mSv/h |

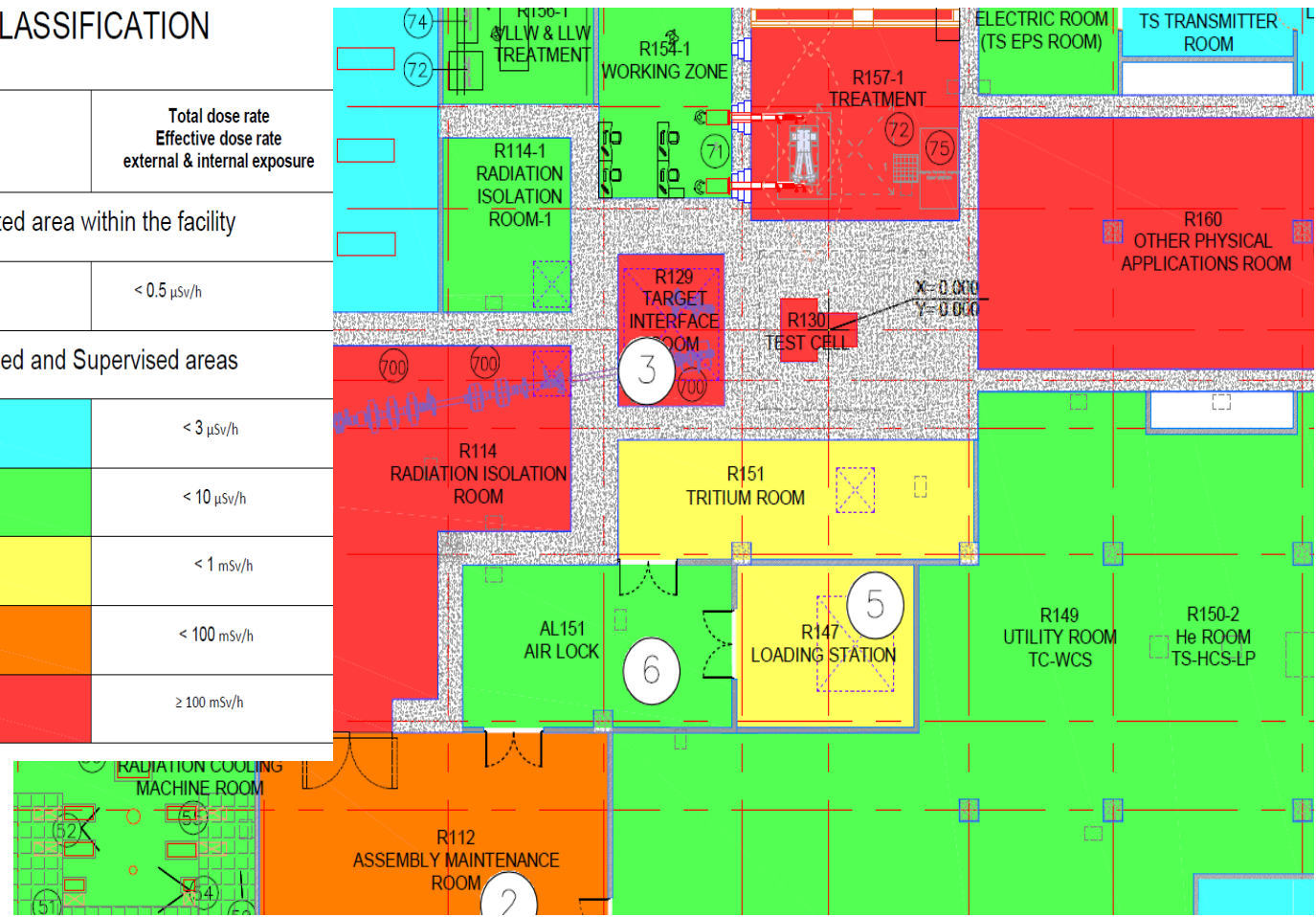

FIRST FLOOR
PLAN VIEW
EL +9.000

Neutron shutter closing time is an order of seconds.

Filters may:

- modify the beam intensity
- modify beam spectrum
- modify beam geometry (collimator)
- split the beam

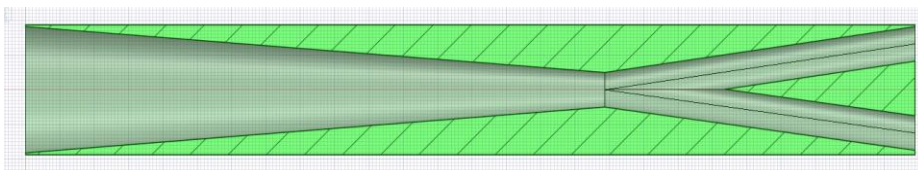
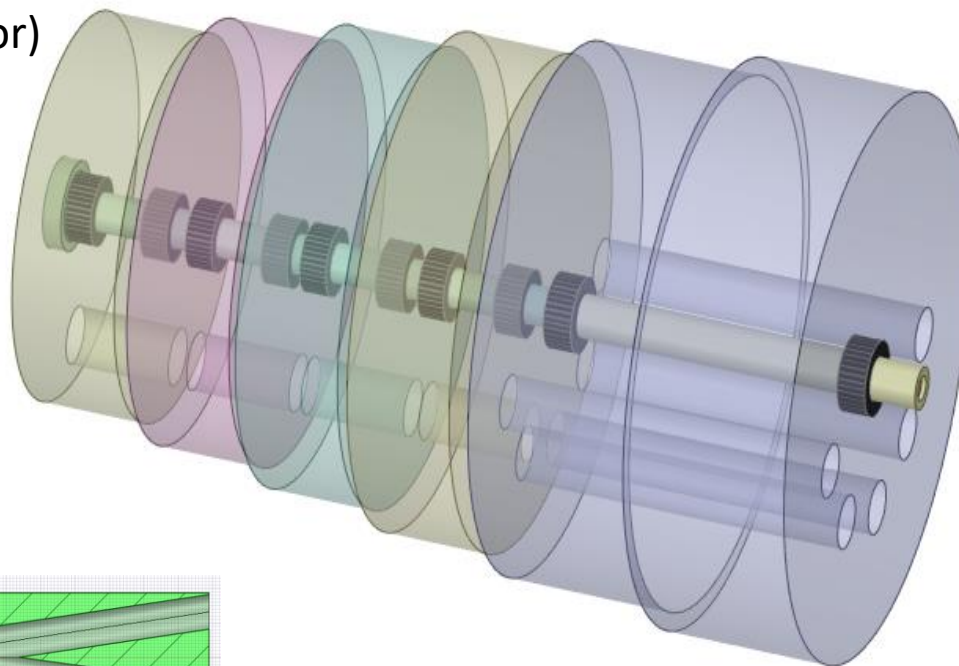

2 x 40 mm diameter

Questions, comments are welcome.

