

# Digital SiPM array with high fill factor and data driven readout for photo detection in liquid noble gas experiments

---

Michael Keller, Peter Fischer, Robert Zimmermann, Michael Ritzert – University of Heidelberg

LIDINE 2023 - Madrid - Spain (22.09.2023)

# Digital SiPMs

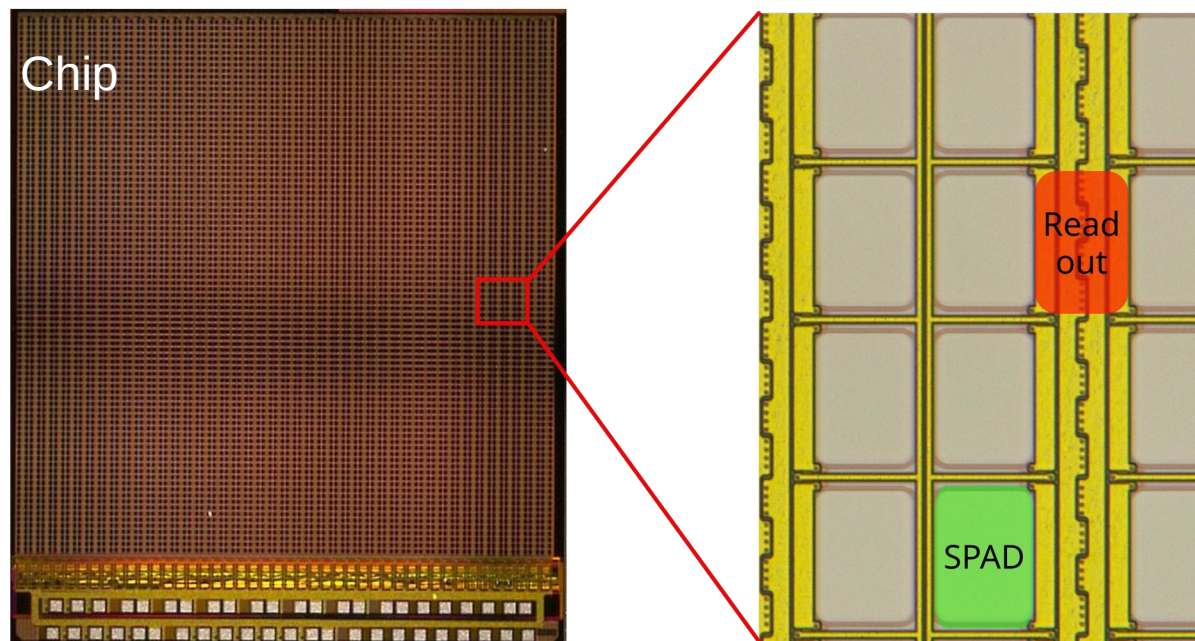

SPADs (single photon detector) and their CMOS readout electronics are manufactured on one silicon chip:

- Fully integrated system with purely digital output signals and simple mechanics
- No power consuming ADCs needed and only few external passive components → low radioactivity
- Noisy („hot“) SPADs can be electronically turned off → much lower overall DCR!
- Lower fill factor and higher noise (compared to standard SiPMs) due to electronics(?)

# SPAD Quality

# Dark Count Rate

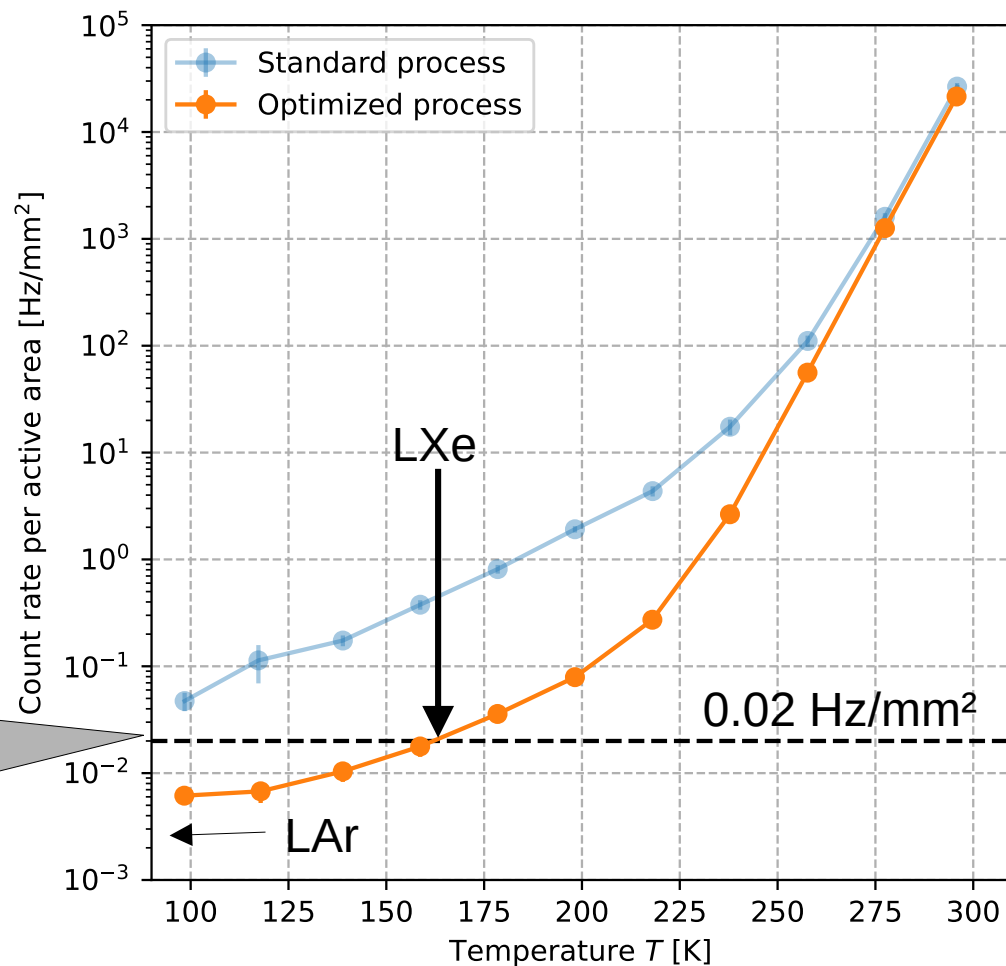

Our Manufacturer IMS improved the DCR at low  $T$  more than an order of magnitude!

## Quantum Efficiency

- IMS has two established processes which offer excellent QE for visible (A) and UV light (B, UV transparent passivation)
- SPADs can be operated with wavelength shifters

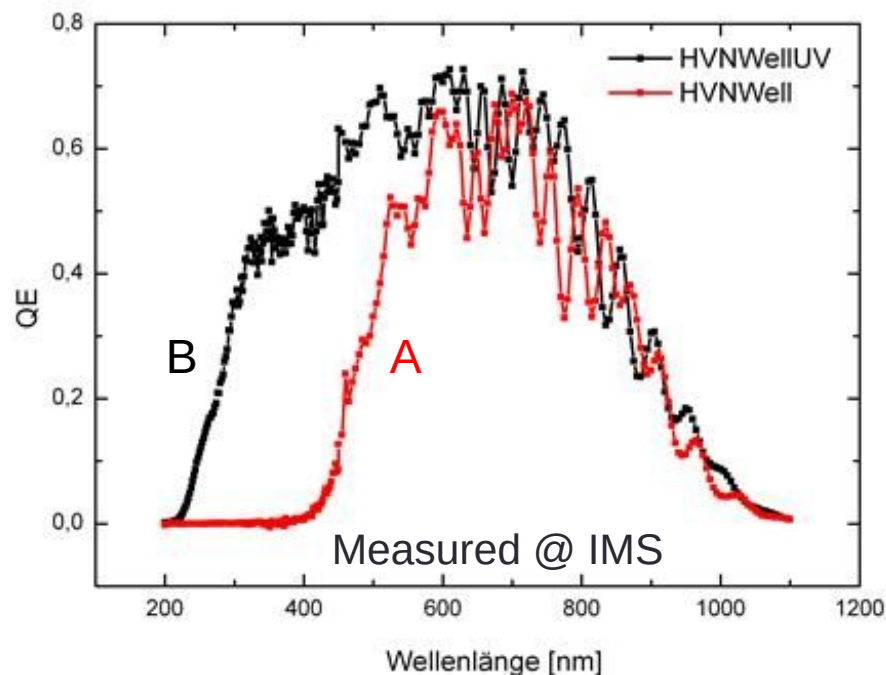

- Deep UV sensitivity can be done but needs new processes. IMS clean room is currently under structural changes.  
→ Production is still delayed (starts now)

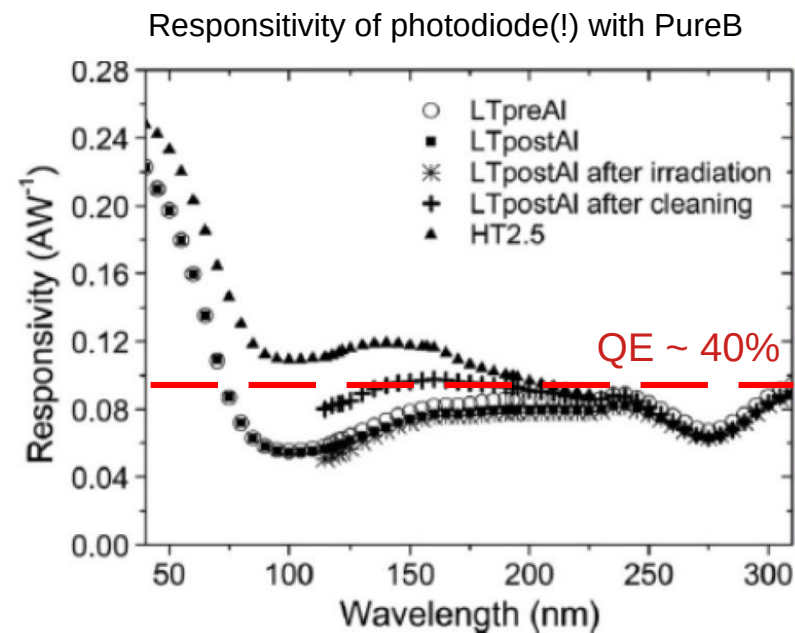

## Laser Setup

- Our existing laser setup was reactivated and optimized
- Sensor scan in XYZ direction with  $< 1 \mu\text{m}$  steps and Laser spot of  $< 5 \mu\text{m}$ .
- We scanned our Digital SiPMs and now started to scan various standard SiPMs for comparison

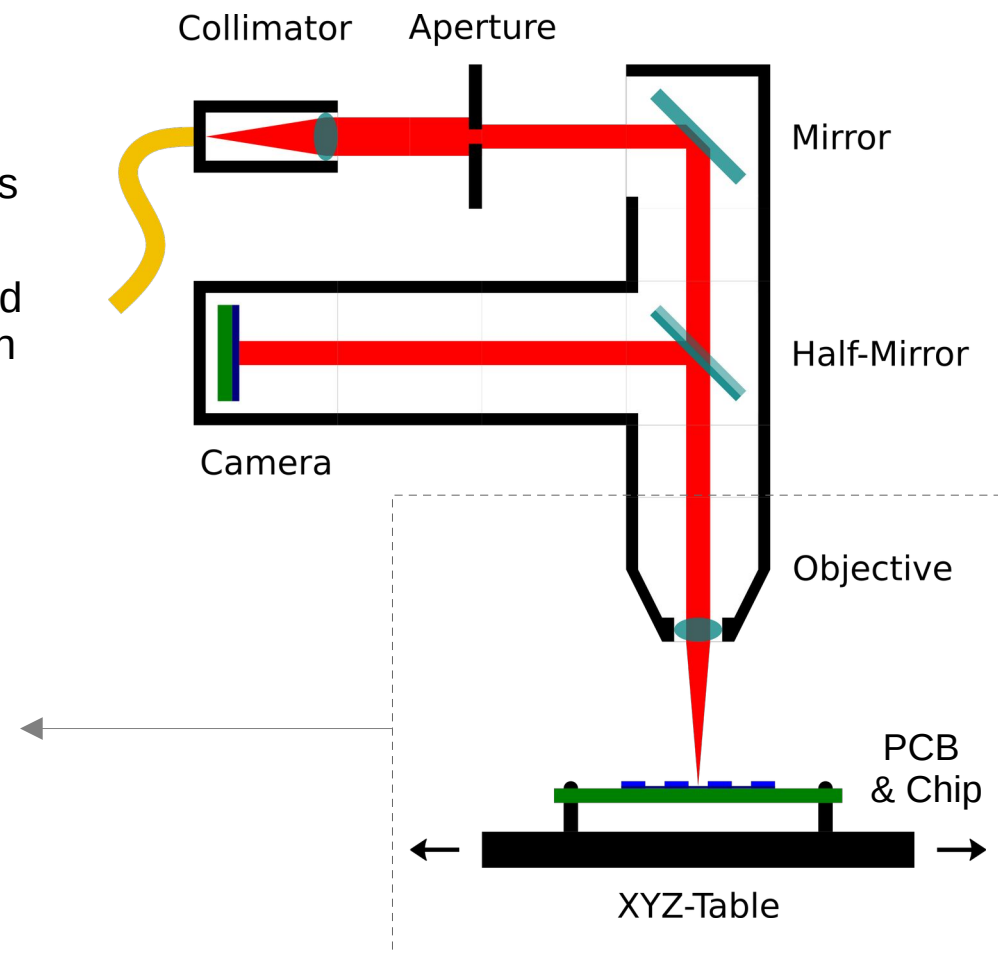
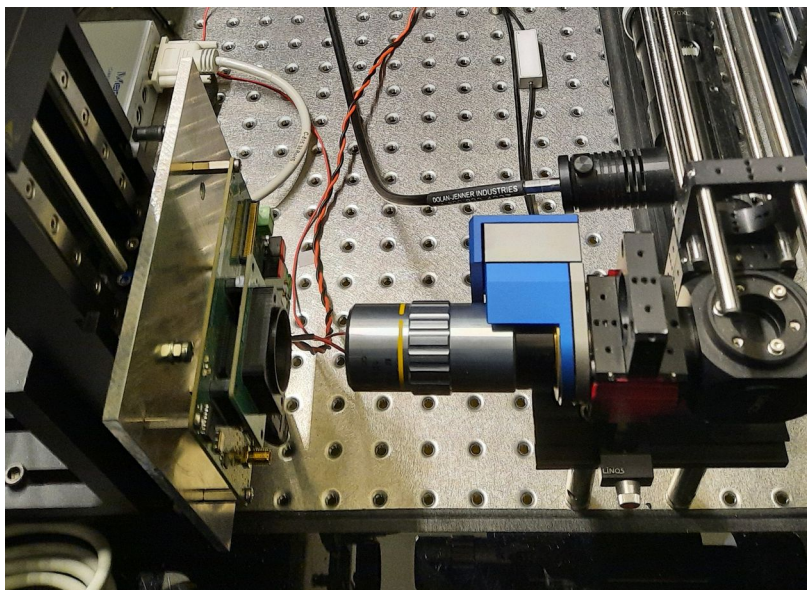

## Spatial Response and Active Region

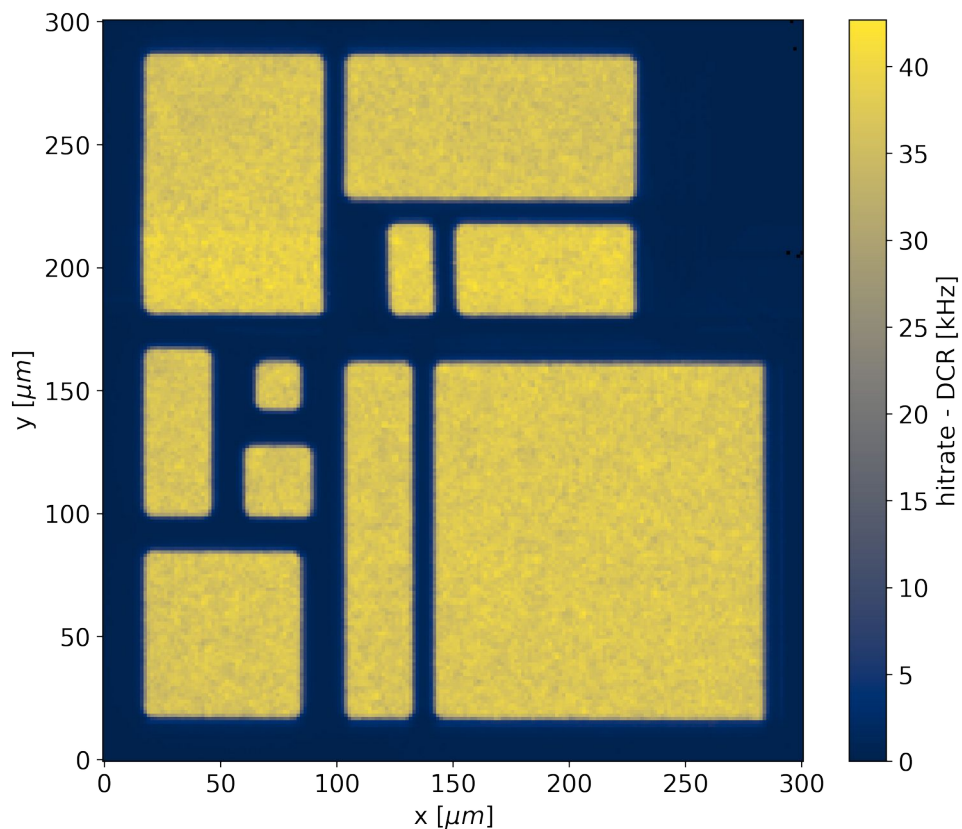

- Scan of DARWIN Test chip, hosting SPADs of different shapes and sizes. (DCR subtracted)
- All SPADs show a very homogeneous spatial response
- Measured active area of all SPAD shapes and sizes is in good agreement with the calculated active area.

| SPAD Size<br>[ $\mu\text{m}^2$ ] | Design Area<br>[ $\mu\text{m}^2$ ] | Measured Area<br>[ $\mu\text{m}^2$ ] |
|----------------------------------|------------------------------------|--------------------------------------|
| 160 x 160                        | 23302                              | 22800 $\pm$ 600                      |
| 80 x 80                          | 5267                               | 5080 $\pm$ 160                       |
| 140 x 70                         | 8303                               | 8200 $\pm$ 200                       |
| 40 x 80                          | 2358                               | 2230 $\pm$ 60                        |

## Hot SPADs and Fill Factor

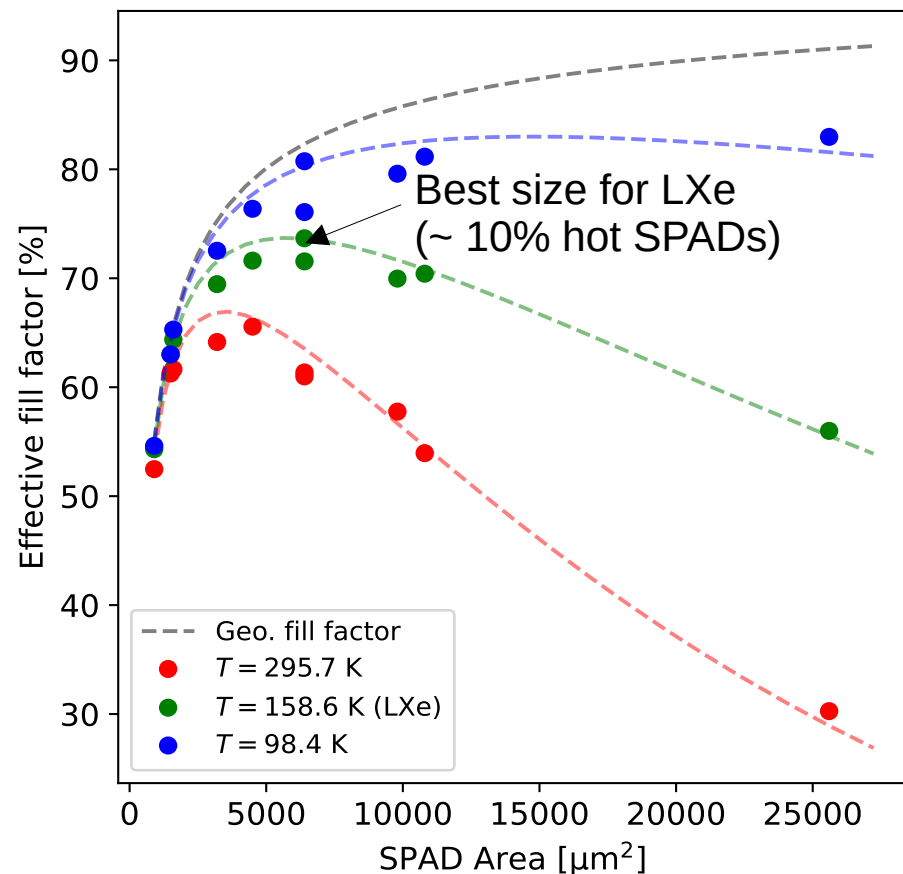

- Hot SPADs have enhanced noise and have to be turned off  $\rightarrow$  reduction of active area / FF
- Fraction of hot SPADs increase with SPAD size, but decreases at low temperatures
- Effective fill factor = geo. FF  $\times$  ( 1 - fraction of Hot SPADs)

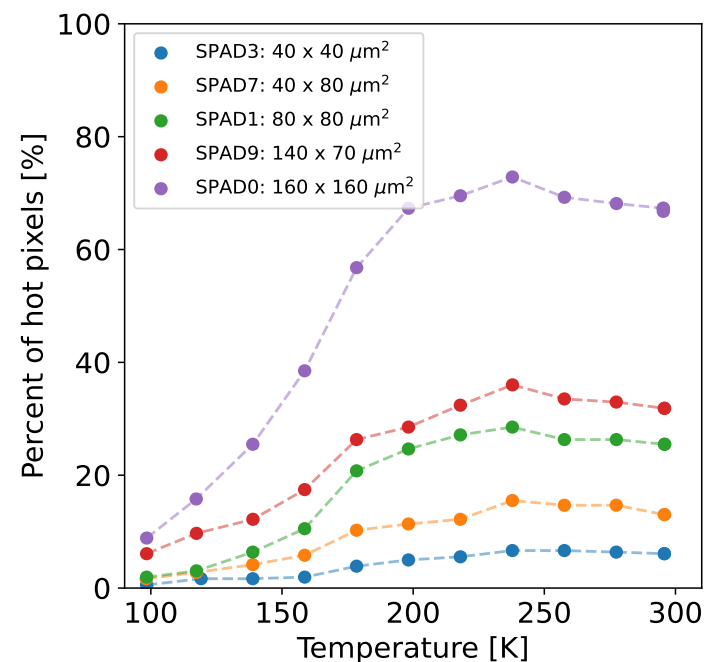



# High fill factor digital SiPM Array

## DARWIN Array

- Development triggered by DARWIN (We are part of the light sensor R&D group)
- Submission done this month!
- Chip area  $\sim 72\text{mm}^2$
- Fill factor is  $\sim 77\%$  (incl. edges etc.)
- Matrix of  $16 \times 60$  Macropixel = 8640 SPADs
- Readout offers:
  - Spatial resolution (x/y  $\sim 300\mu\text{m}$ )
  - Event time-Stamped ( $\Delta t \sim 10\text{ns}$ )
  - Serial data output (low number of pads)
- Daisy chaining of up to 64 chips to build detector modules

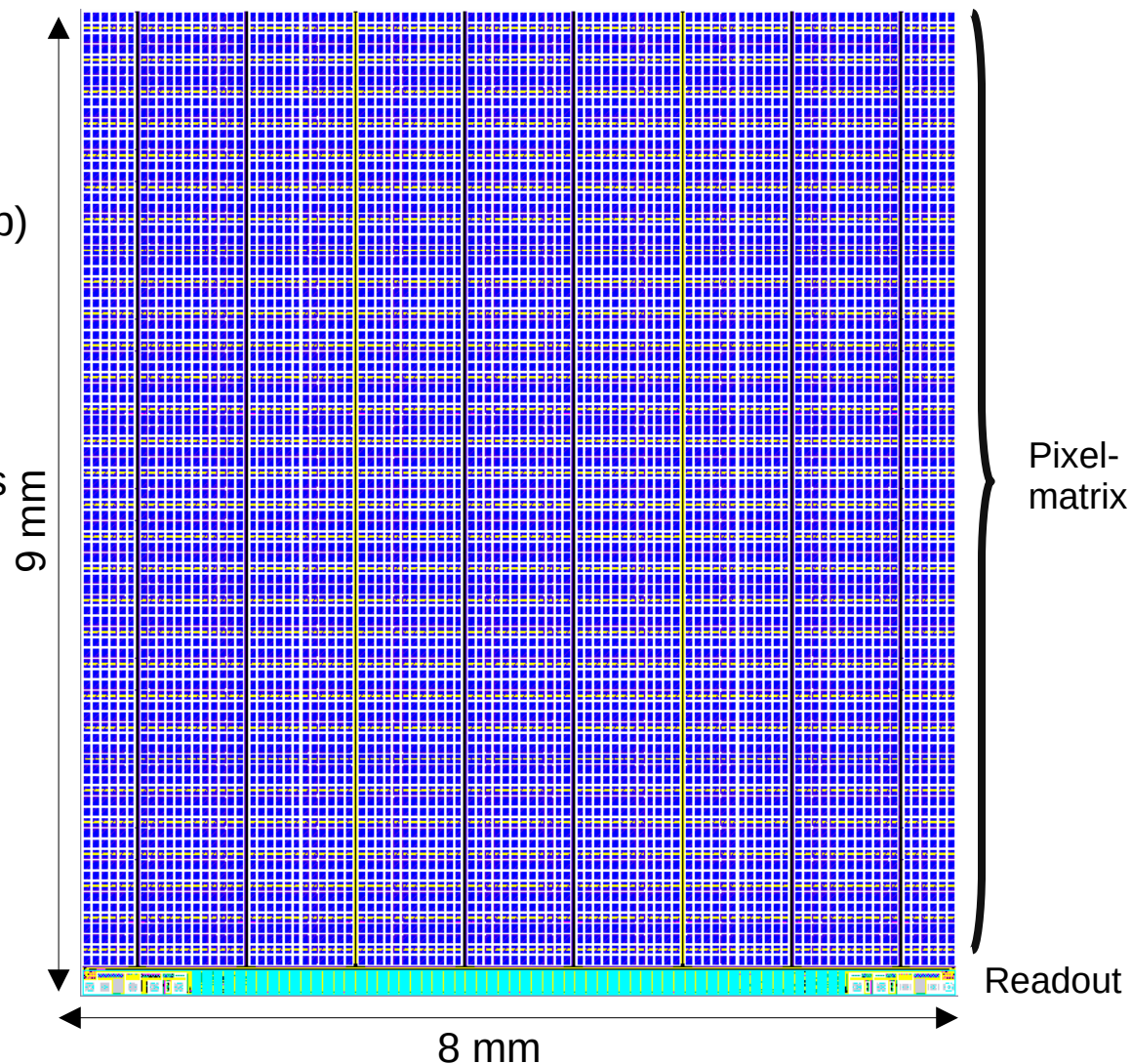

## Macropixel

- Macropixel comprises 9 SPADs. Each SPAD can be disabled if noisy. Hit = Logical OR of all SPADs
- 4 macropixels share one block of readout electronics:
  - Mask Bits, Test Inject, 1Bit FlipFlop for Hit
  - A hit pixel sends a static X- and a Y- signal to the periphery

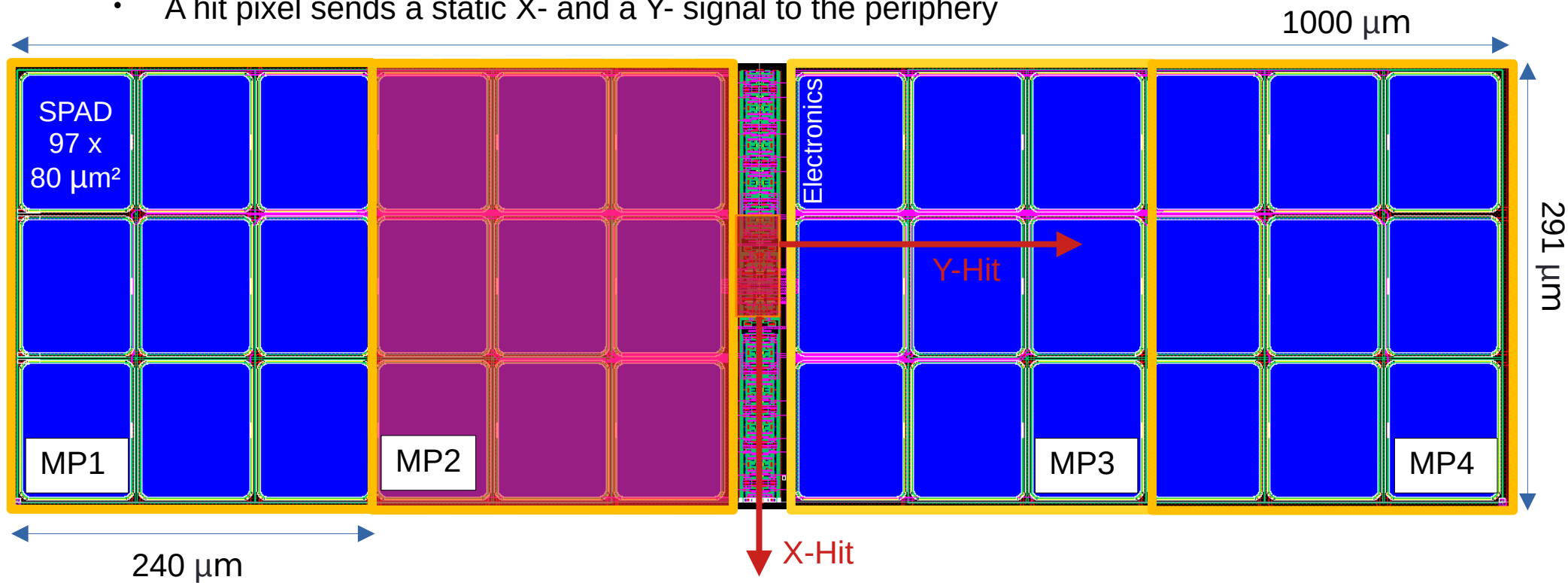

# Macropixel – Electronics

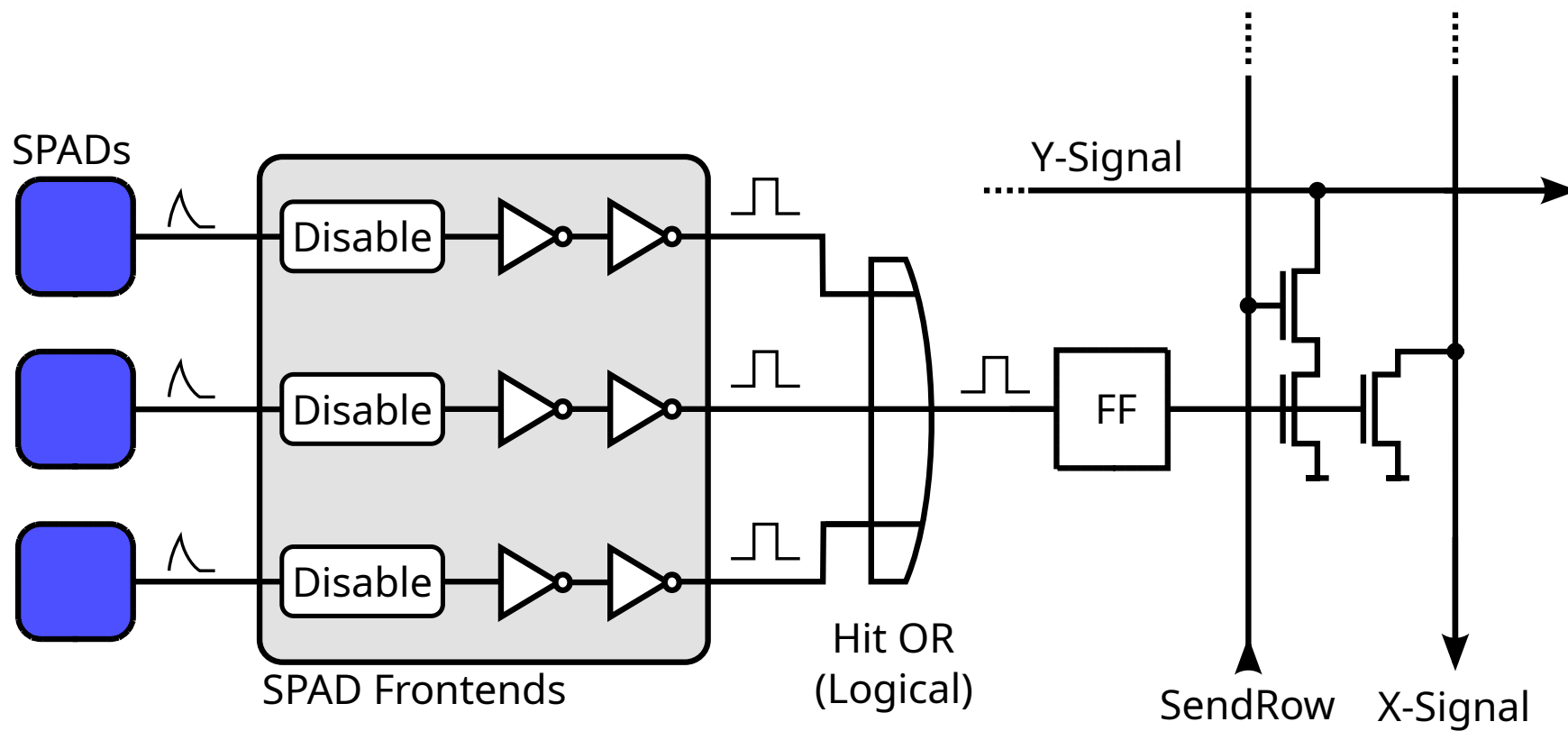

## Readout

- Data Driven Logic “squeezed” between bond pads. Fully synthesized from HDL-code. (Low power consumption, which scales roughly linear with photon occupancy)

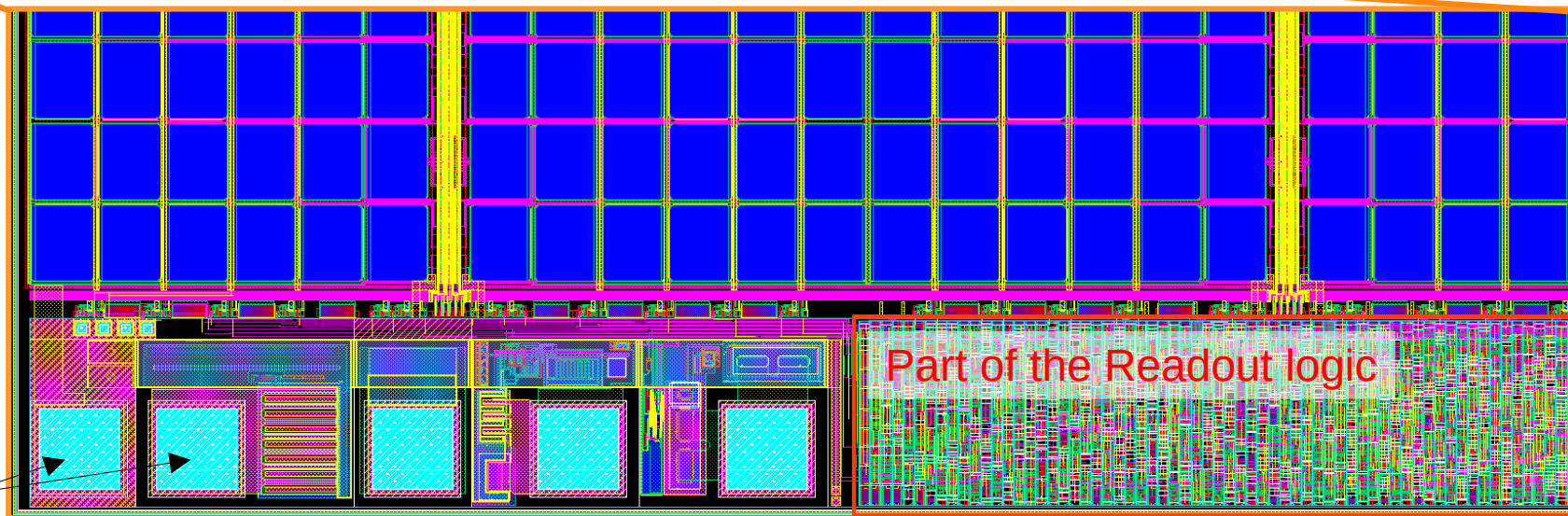
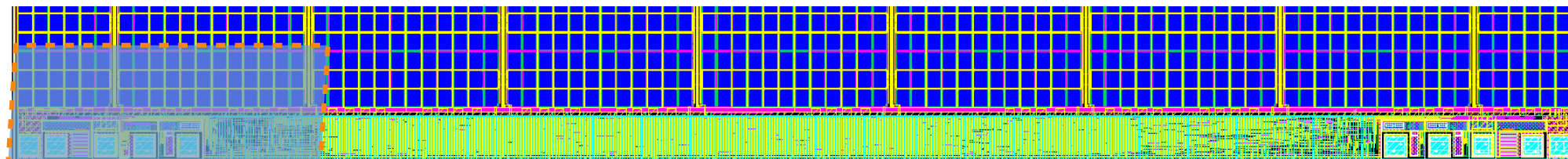

Bond pads

Part of the Readout logic

# Hit Finding

The chip delivers X-Y-T information for EACH hit macropixel:

- All hits are flagged to periphery via X-Y-signals  
Multiple active X-Y-signals are possible for multiple hits!
- A priority readout logic
  - Chooses one column with active X-signal (prioritizes highest X address)
  - Finds *the first associated Y-signal*
  - converts X/Y to an (binary) address
  - assigns a column wise time stamp ( $1/(2 \cdot \text{CLK})$  resolution, recorded when first(!) X-Signal of column arrives.)
  - stores the hit in an on-chip FIFO (32 words)
- Scan continues until all columns are processed
  - 60 ns / Hit in same column
  - 160 ns / Hit in different column @ 50 MHz chip clock

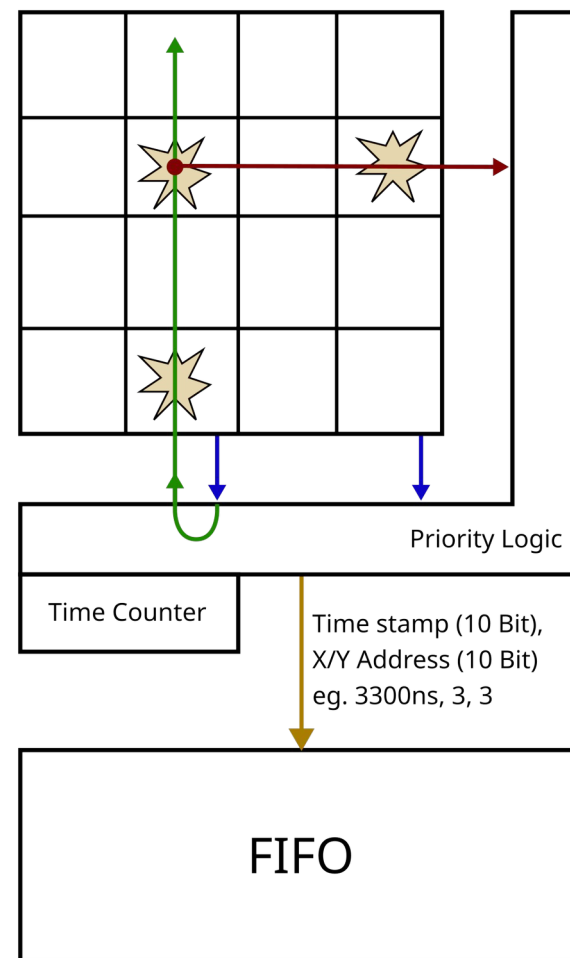

## Data Readout

- FIFO is emptied on one serial line
  - 6 Bit ID (unique for each chip)
  - 10 Bit XY Address
  - 10 Bit Time stamp (20.5 us epoch)
- Hit data can propagate through a daisy chain of (up to 64) chips.
- Default clock speed is 50 MHz
- One global CMD signals controls everything
- 7 chip signals (10 Bond Pads):
  - 4 digital, as shown
  - 2 supply (power, ground)
  - 1 HV for SPAD

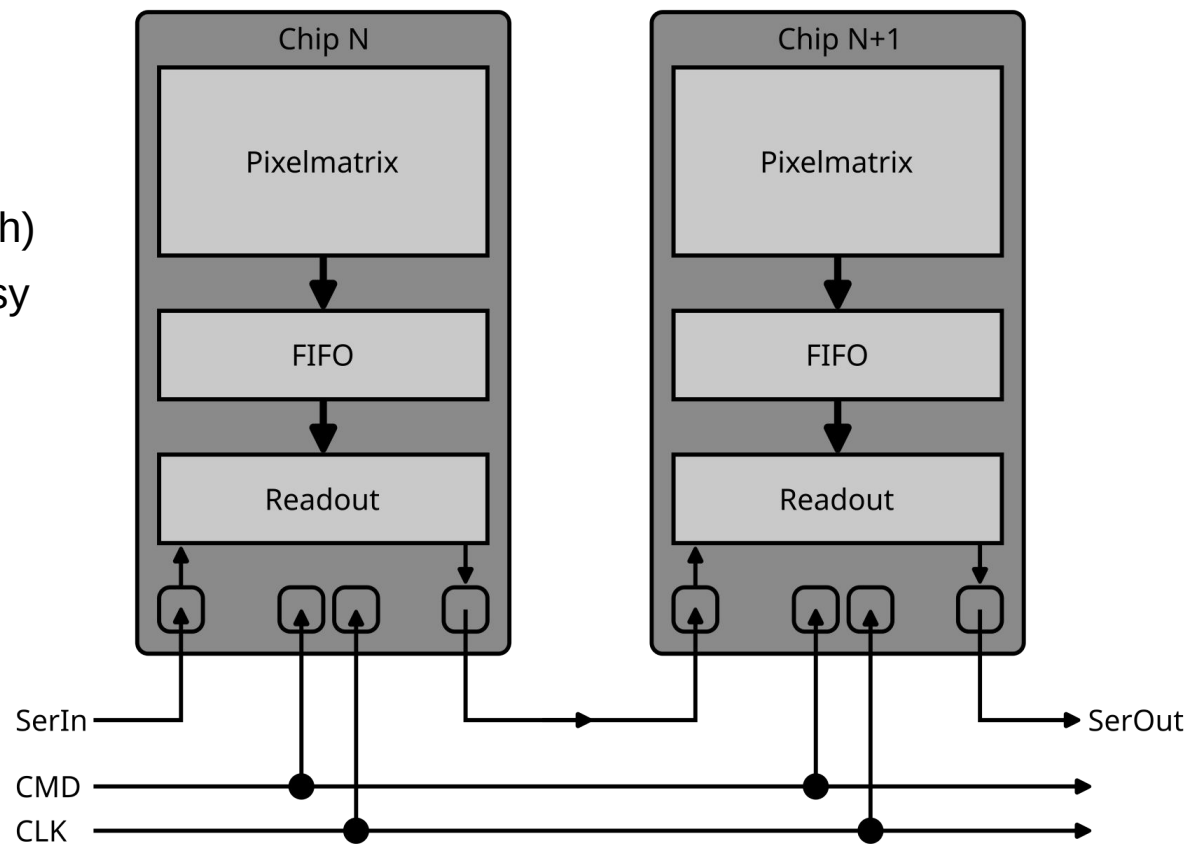

# Chain Simulation

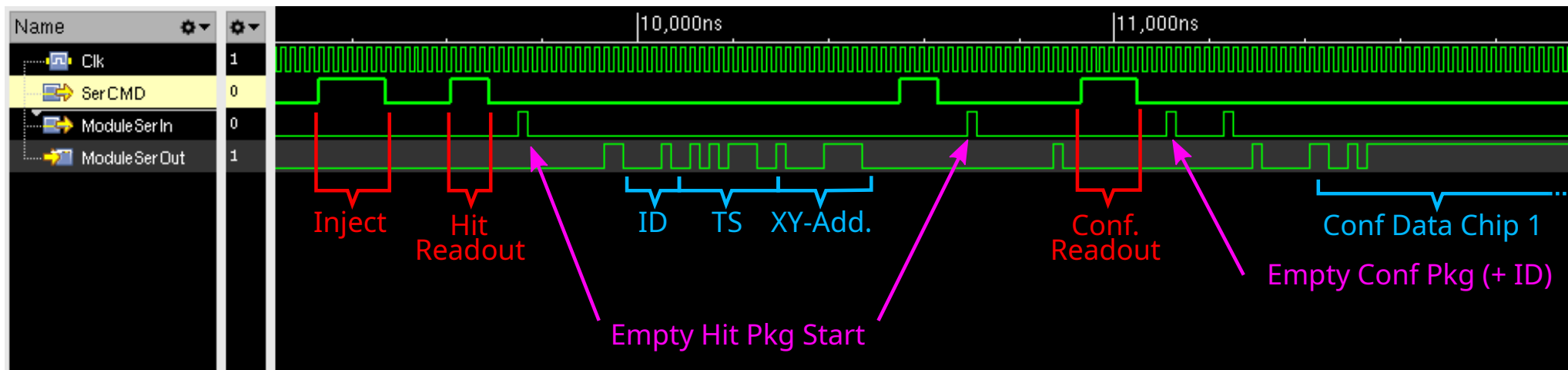

Simulation of a chain of 3 chips:

- 1) Only one pixel (7/33) on chip 2 has been activated (not shown)
- 2) Electrical injection is performed in all chips.
- 3) Two hit readout CMDs are given. Since only one pixel is active, only one bit string is send.
- 4) Configuration register of chip 1 is read. (not all bits are shown)



## Rate Limits (@ CLK = 50 MHz, conservative)

Continuous rate of photons:

- Sending hit to FIFO takes 160 ns.
- Readout of 26 Bit hit data requires 520 ns

→ rate limited by readout speed

- ~ 1.8 Mevents / chain / s
- ~ **1.6 kEvents / mm<sup>2</sup> / s** (@ 16 chips / chain)

Instantaneous burst of photons:

- Hits remain stored in macro pixel *until they are read out!* (Serial Readout can take long)
  - (Successive hits in same column get wrong time stamps)
- Pileup due to macropixel size (0.07 mm<sup>2</sup> ~ 14 pixels/mm<sup>2</sup>)
- Example: For **1 hit/mm<sup>2</sup>** in all chips, **full readout requires 600 μs** (@ 16 chips / chain)

If the photon occupancy surpasses chain readout speed or the macro pixels are occupied when the next burst is happening **photons are lost** (Currently simulations are done to quantify this)

## Module Concept

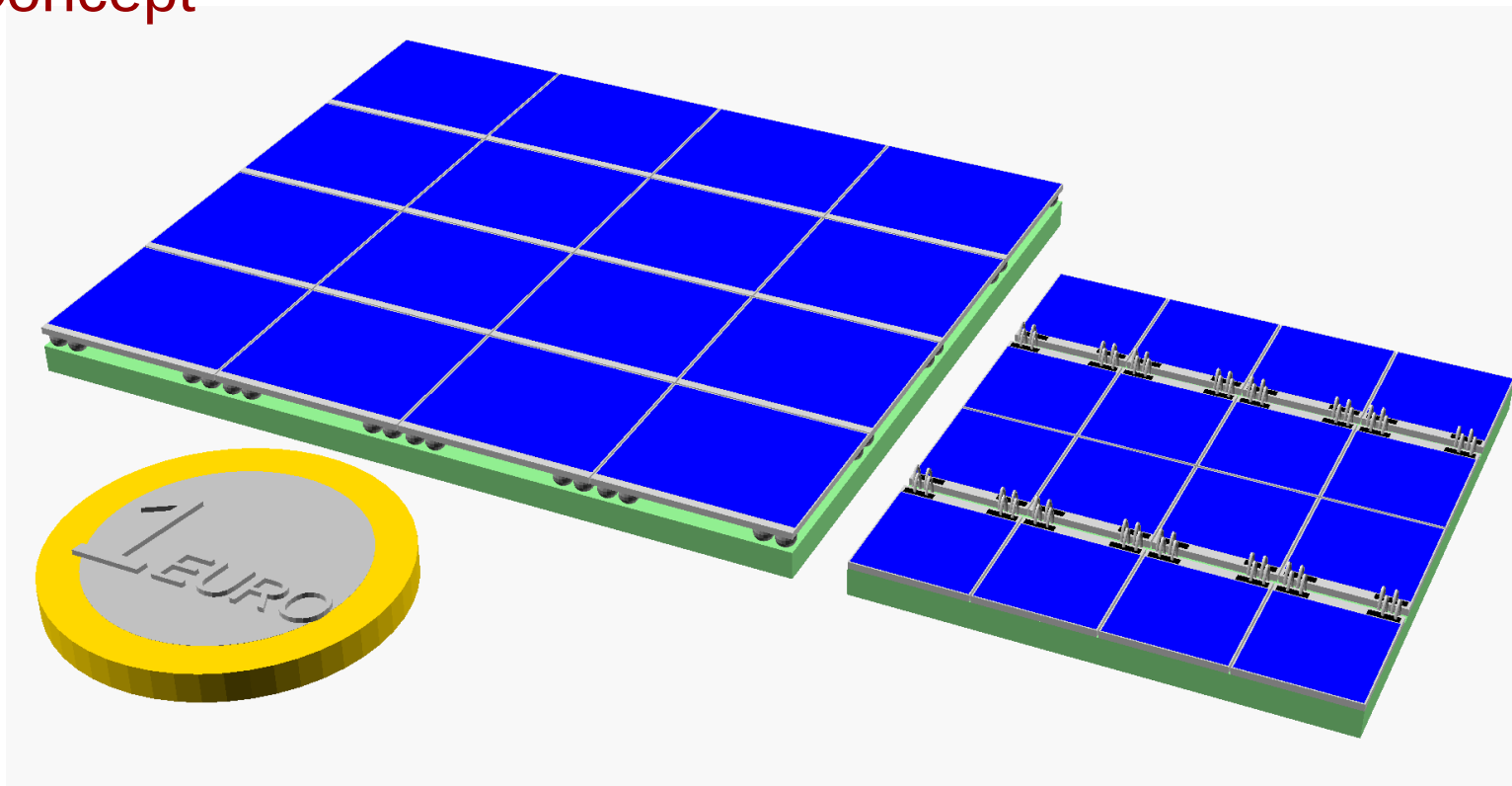

- Module with 16 – 64 chips. Low activity substrate as support structure and for electrical contacting. No further passive components are needed.
- Option: Bond pads can be contacted by Through Silicon Vias (TSV) → increase module fill factor. Test implementation of TSVs is planned!

## Next Steps

- Test of DARWIN Array
  - Will receive the chips from IMS in March 2024
  - Will be produced with standard QE and DCR :-(
  - Building a small 2 x 2 Chip module
- Production of the deep UV sensitive SPADs starts (after a long delay) at IMS
- A DSiPM array will be operated in liquid Xenon (cooperation with the KIT and University of Freiburg, we start in October 2023!)
- Finalize Fill Factor measurement for standard SiPMs (Robert has tested a Hamamatsu and FBK SiPMs)
- Radio-purity test → IMS is gathering a larger amount of samples
- Simulation of rate limits and photon loss scenarios in DARWIN TPC environment
- SPAD light emission studies