

# Development of real-time digital twin for particle accelerator

Mahshid Mohammad Zadeh, J. Gethmann, A.-S. Müller and G. De Carne

## Introduction

### Motivation

Accelerators are complex and energy-intensive, needing a stable power supply usually from the public grid. Their inflexibility in power adjustment, especially with large inflow of renewable power generation, complicates grid management as they require constant power regardless of grid conditions.

### Solution

The ACCESS project aims to create a digital twin for the Karlsruhe Research Accelerator (KARA) to develop and test new energy solutions without interrupting ongoing research. This requires a comprehensive measurement system and high-speed communication infrastructure to continuously update the digital twin with real-time data, ensuring accurate monitoring and responsive decision-making in KARA's dynamic environment.

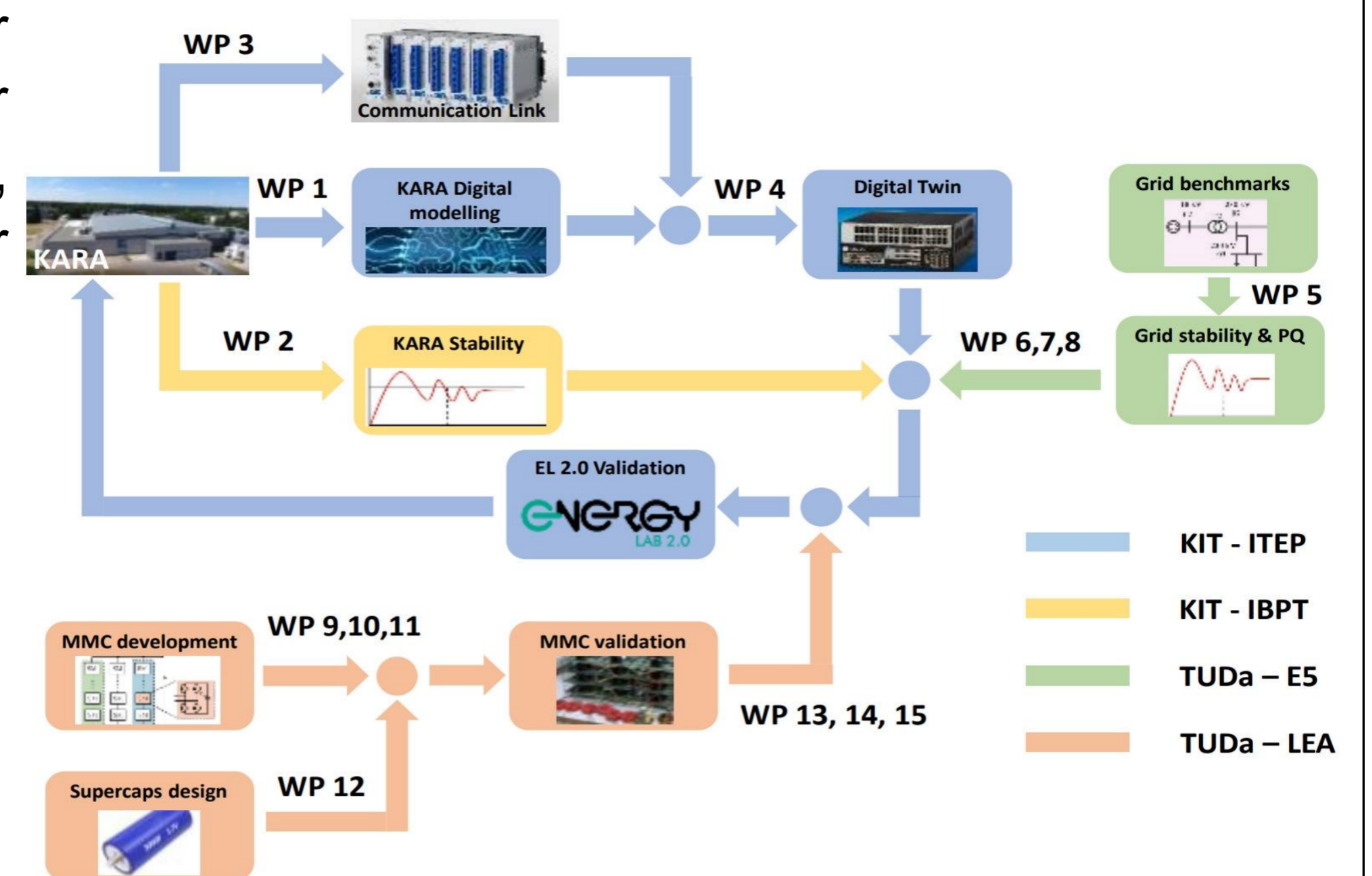

## Communication Infrastructure

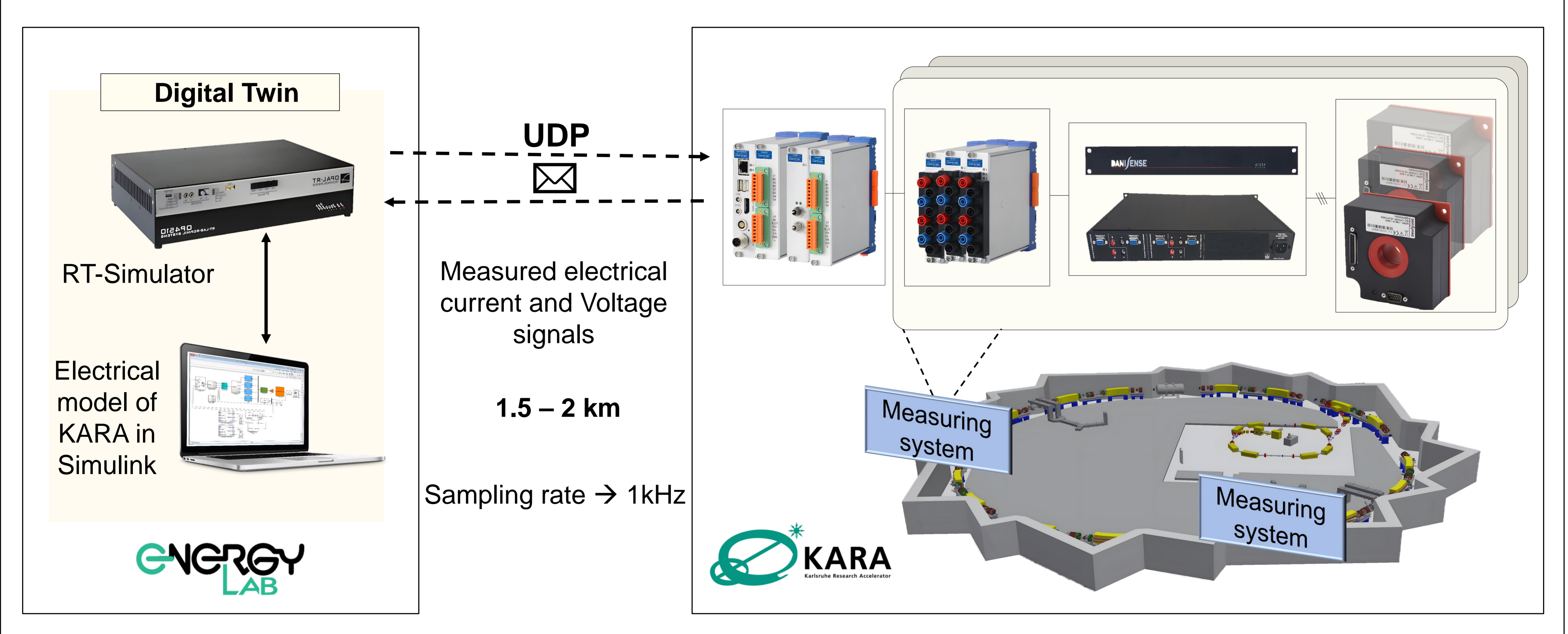

## Transferred Data

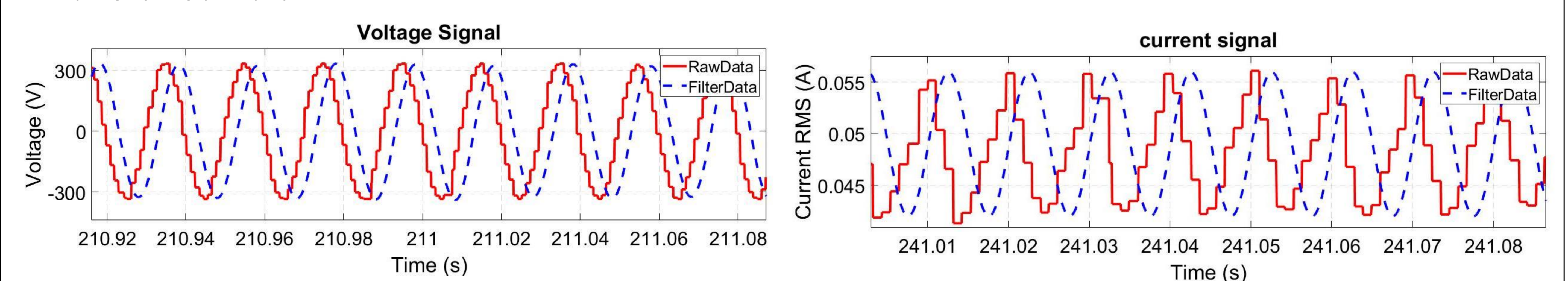

## Next Steps

- Implement the full electrical model of the KARA accelerator in the digital real-time simulator
- Real-time transfer of the electrical variables measurement in the simulated model: real-time digital twin
- Power Hardware In the Loop testing of new hardware and control energy solutions for accelerators
- Real-time monitoring of KARA and provision of corrective feedback to improve online the energy usage

**Acknowledgment:** This work has been supported by the BMBF Project "ACCESS" (Grant No.05K2022).