

A Compact Detector for EXotics at LHCb: CODEX-b

Carlos Vázquez Sierra  (IGFAE/USC) [<https://cvazquez.notion.site/>]
Seminario CIEMAT Física de Partículas (CFP), 23rd of May 2024



IGFAE

Instituto Galego de Física de Altas Enerxías



XUNTA
DE GALICIA

CODEX-b



The Standard Model (SM) of elementary particles:

- Most **successful theory** describing subatomic particles and their interactions.
- Accommodates strong, weak and electromagnetic interactions:

$$G_{\text{SM}} = G_{\text{QCD}} \times G_{\text{EW}} = \text{SU}(3)_C \times \text{SU}(2)_L \times \text{U}(1)_Y$$

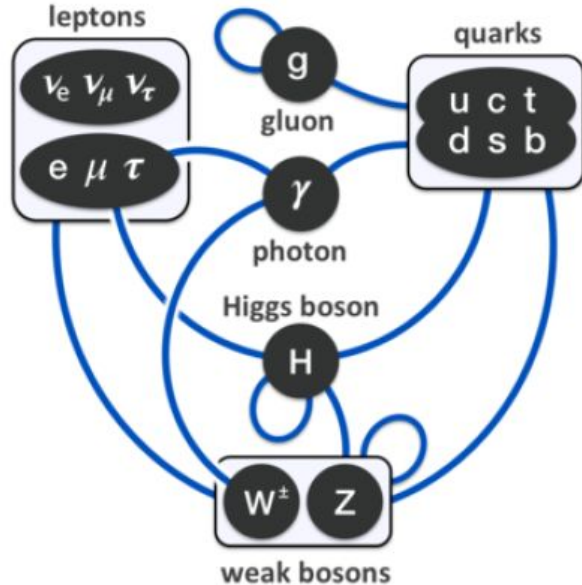

SM is strongly predictive and precise:

- t predicted (observed) on 1973 (95),
- W/Z predicted (observed) on 1962 (83),
- g predicted (observed) on 1962 (78),
- H predicted (observed) on 1964 (2012),
- Good agreement with experimental results.

The Standard Model (SM) of elementary particles:

- Most **successful theory** describing subatomic particles and their interactions.
- Accommodates strong, weak and electromagnetic interactions:

$$G_{SM} = G_{QCD} \times G_{EW} = SU(3)_C \times SU(2)_L \times U(1)_Y$$



THE STANDARD MODEL: IT HAS TO BREAK DOWN AT SOME POINT BUT JUST KEEPS CHUGGING ALONG!

MCK, COSM2014

But also an incomplete theory:

- Inability to explain gravity.
- Dark matter and dark energy.
- Baryogenesis problem (BNV, CPV).
- Towards a GUT (gauge unification).
- Neutrino masses.
- Hierarchy problem and fine-tuning.

A Direct Empirical Proof of the Existence of Dark Matter*

Douglas Clowe¹, Maruša Bradač², Anthony H. Gonzalez³, Maxim Markevitch^{4,5}, Scott W. Randall⁴, Christine Jones⁴, and Dennis Zaritsky¹

Published 2006 August 30 • © 2006. The American Astronomical Society. All rights reserved. Printed in U.S.A.

[The Astrophysical Journal, Volume 648, Number 2](#)

Citation Douglas Clowe *et al* 2006 *ApJ* **648** L109

DOI 10.1086/508162

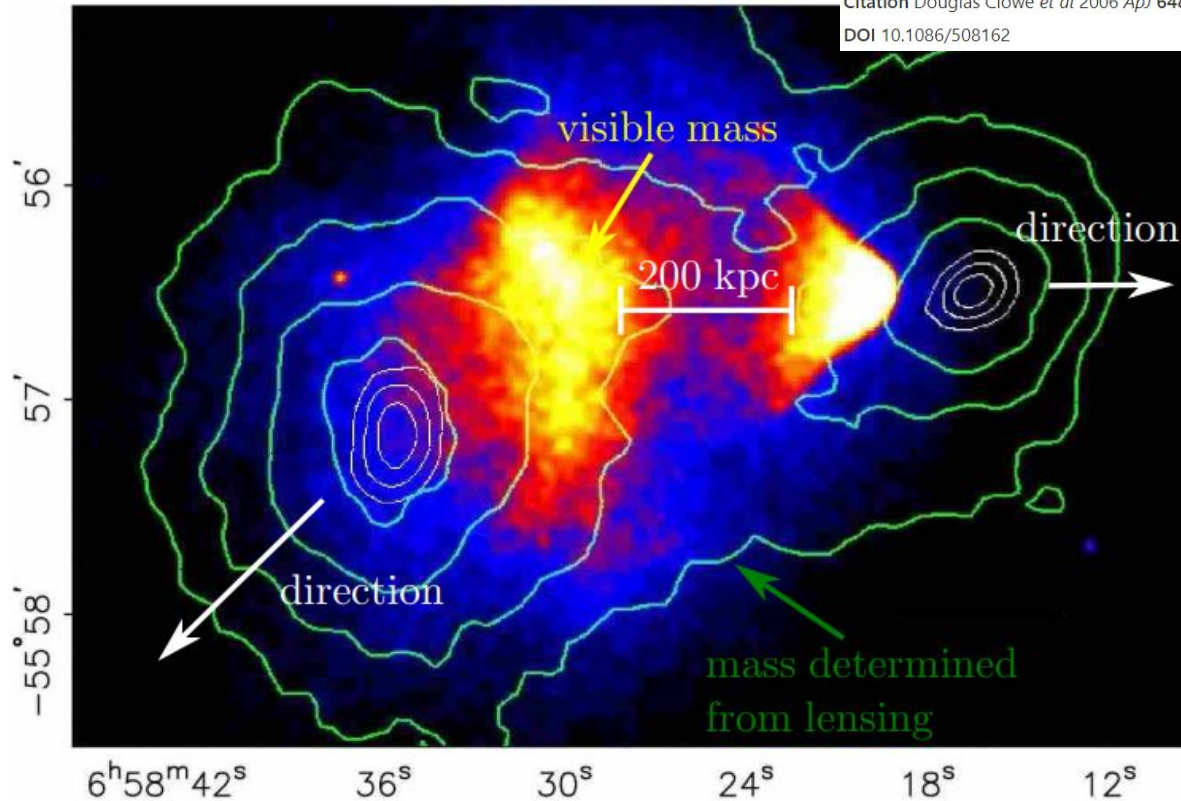

Dark Matter

Canción • Pearl Jam

Still no New Physics?

Maybe...

The New Physics scale is higher than expected?

We need **bigger** colliders working at higher energies, with higher precisions.... large technological and financial requirements...

Still no New Physics?

Maybe...

The New Physics

We need **bigger** c
technological and



precisions... large

Still no New Physics?

Maybe...

The New Physics scale is higher than expected?

New Physics operates in “*Stealth*” mode?

New Physics exists at the electroweak scale, could be discovered in colliders, but with **heavy mediators, tiny couplings, large backgrounds...**

Still no New Physics?

Maybe...

Reports on Progress in **Physics**











The New PI

New Physic

REPORT ON PROGRESS

Unleashing the full power of LHCb to probe stealth new physics

New Physic
with heavy

M Borsato¹ , X Cid Vidal^{38,2} , Y Tsai^{3,4} , C Vázquez Sierra⁵ , J Zurita⁶ , G Alonso-Álvarez⁷ ,
A Boyarsky⁸ , A Brea Rodríguez² , D Buarque Franzosi^{9,10} , G Cacciapaglia^{11,12} 

▼ Show full author list

Published 16 February 2022 • © 2022 IOP Publishing Ltd

[Reports on Progress in Physics, Volume 85, Number 2](#)

Citation M Borsato *et al* 2022 *Rep. Prog. Phys.* **85** 024201

DOI 10.1088/1361-6633/ac4649

iders, but

Still no New Physics?

Maybe...

The New Physics



New Physics

New Physics
with heavy

Reports on Progress in Physics

REPORT ON PROGRESS

Unleashing the full power
of physics

M Borsato¹ , X Cid Vidal^{38,2} , Y Tsai³,
A Boyarsky⁸ , A Brea Rodríguez² , D

[Show full author list](#)

Published 16 February 2022 • © 2022 IOP Publishing

[Reports on Progress in Physics, Volume 85, Number 2](#)

Citation M Borsato et al 2022 Rep. Prog. Phys. 85 024001

DOI 10.1088/1361-6633/ac4649

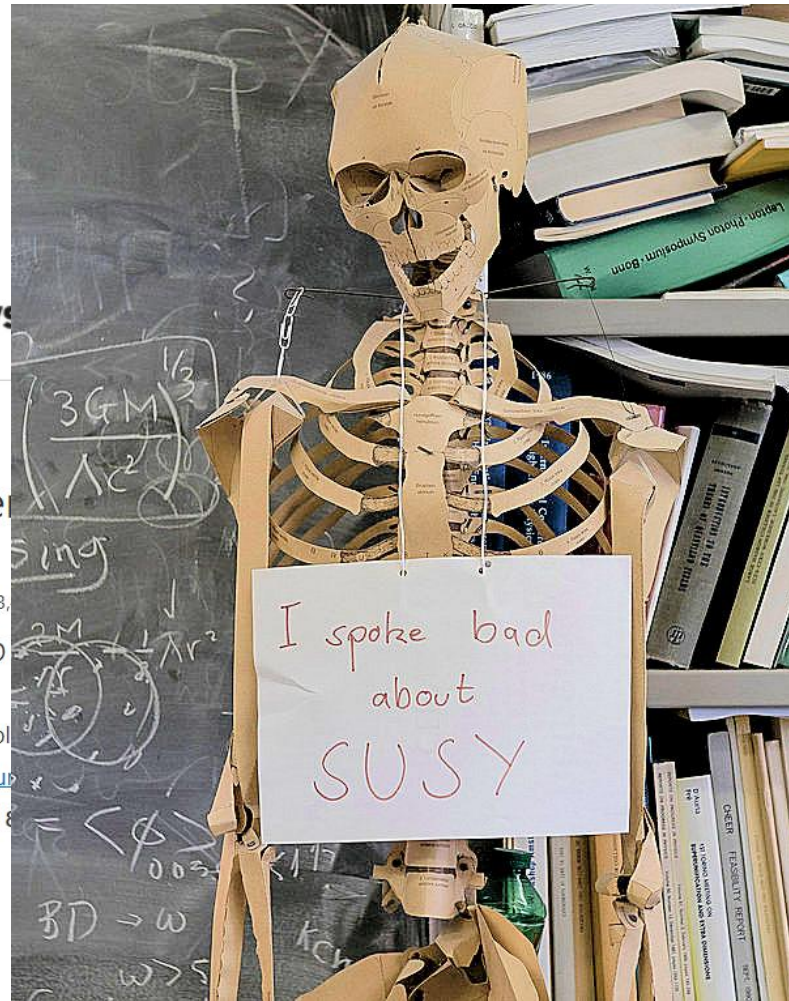

ders, but

Still no New Physics?

Maybe...

The New Physics scale is higher than expected?

New Physics operates in “*Stealth*” mode?

New Physics requires of unconventional search strategies?

New phenomena does not happen strictly around the interaction point in colliders, or will not happen at such high energies?

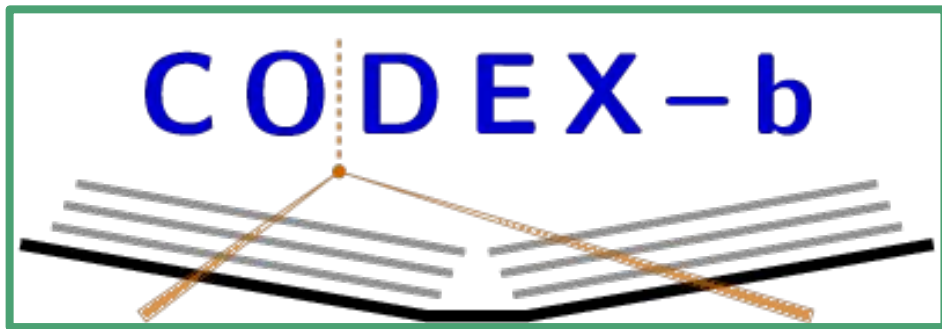

SHiP
Search for Hidden Particles

LHC-based

Non-LHC based

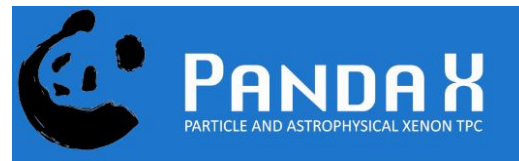

LUX-ZEPLIN (LZ)
DARK MATTER SEARCH

Search for feebly interacting long-lived particles (LLPs)

Small coupling with SM \rightarrow large lifetime (e.g. dark sectors).

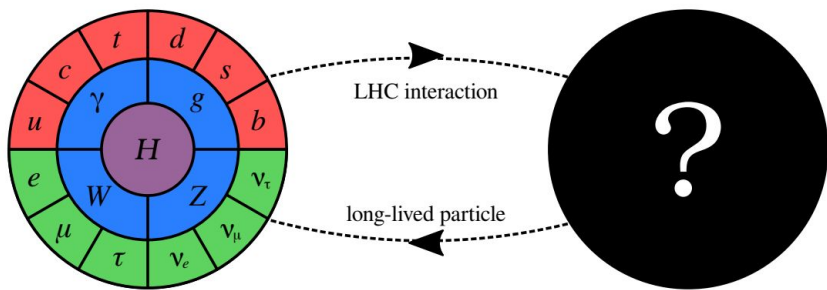

LHC conventional searches typically focused on shorter lifetimes, higher masses.

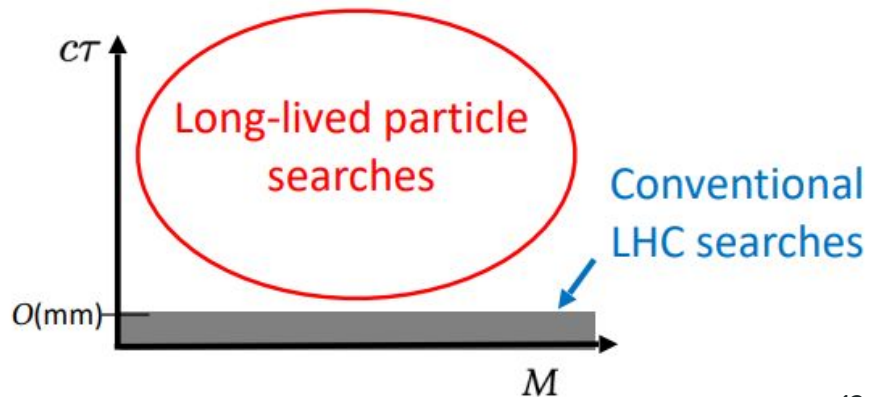
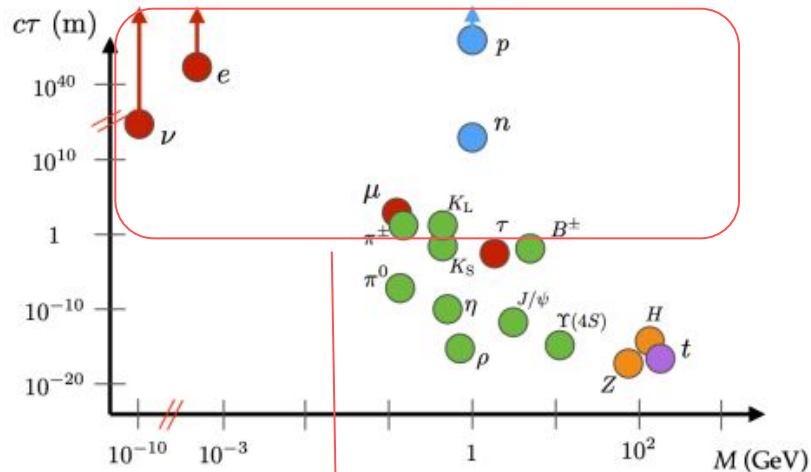

Complex and diverse model space → sometimes very complicated signatures.

Huge efforts at major collaborations (ATLAS, CMS, LHCb) required to design and develop dedicated triggers, reconstruction algorithms, and even complicated simulation models.

These detectors were not originally designed for these kind of searches.

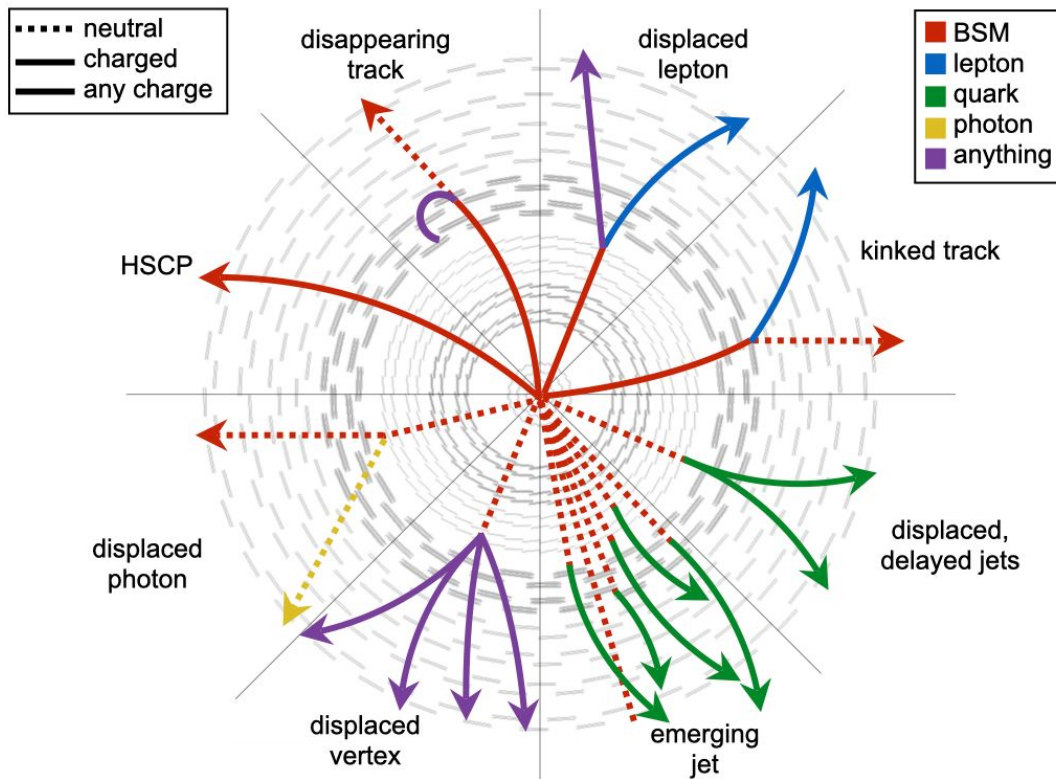

Complex and diverse model space → sometimes very complicated signatures.

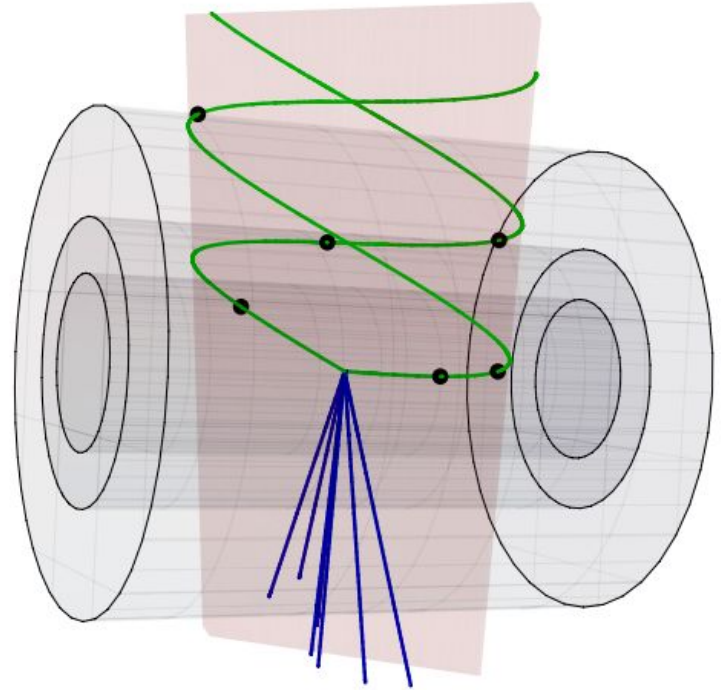
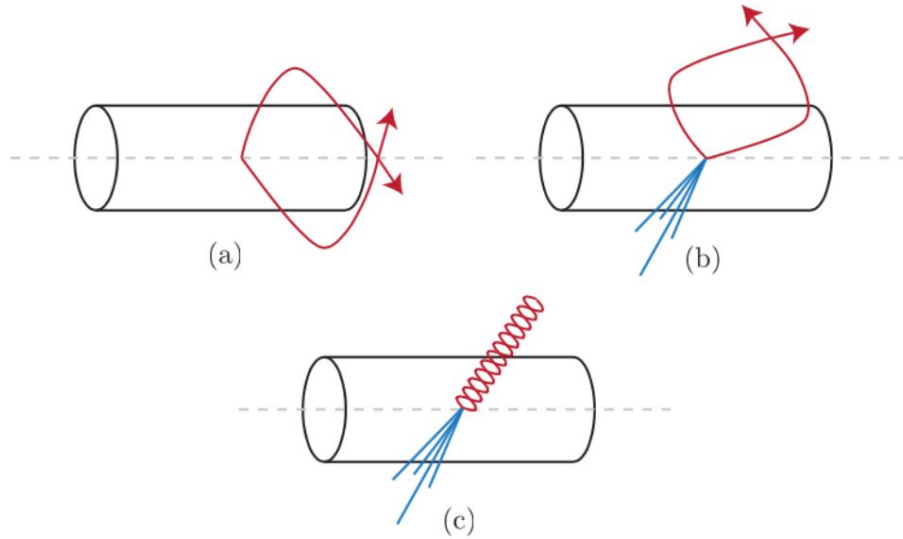

[arXiv:0805.4642](https://arxiv.org/abs/0805.4642) “Macroscopic strings and **quirks** at colliders”

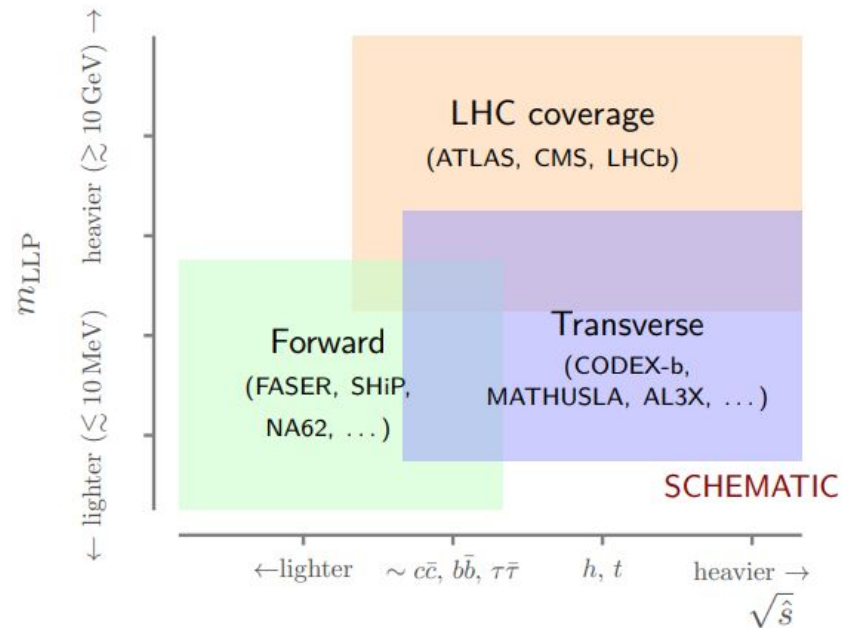
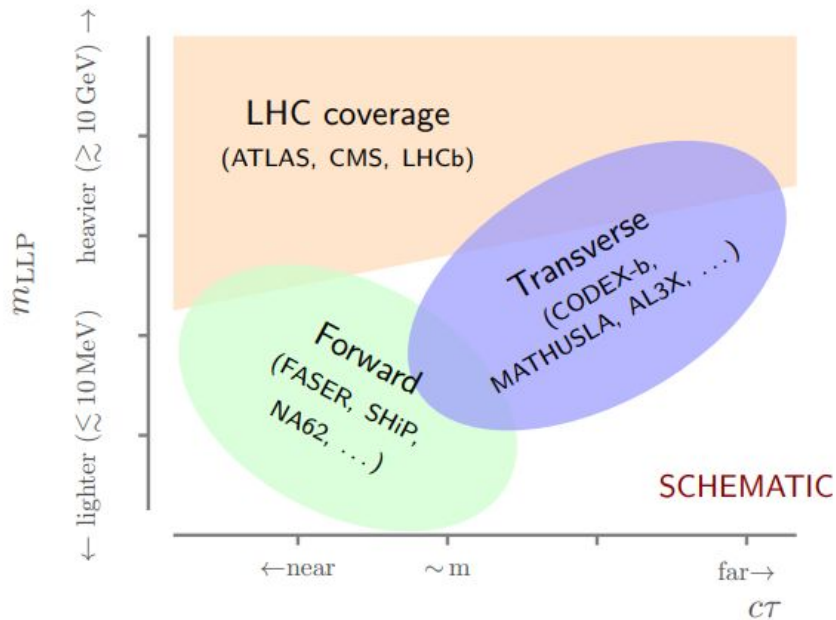

Propose new, dedicated LLP detectors to cover the inaccessible gaps of the parameter space.

Rely on simpler reconstruction and tracking systems, much more flexible to accommodate unusual signatures.

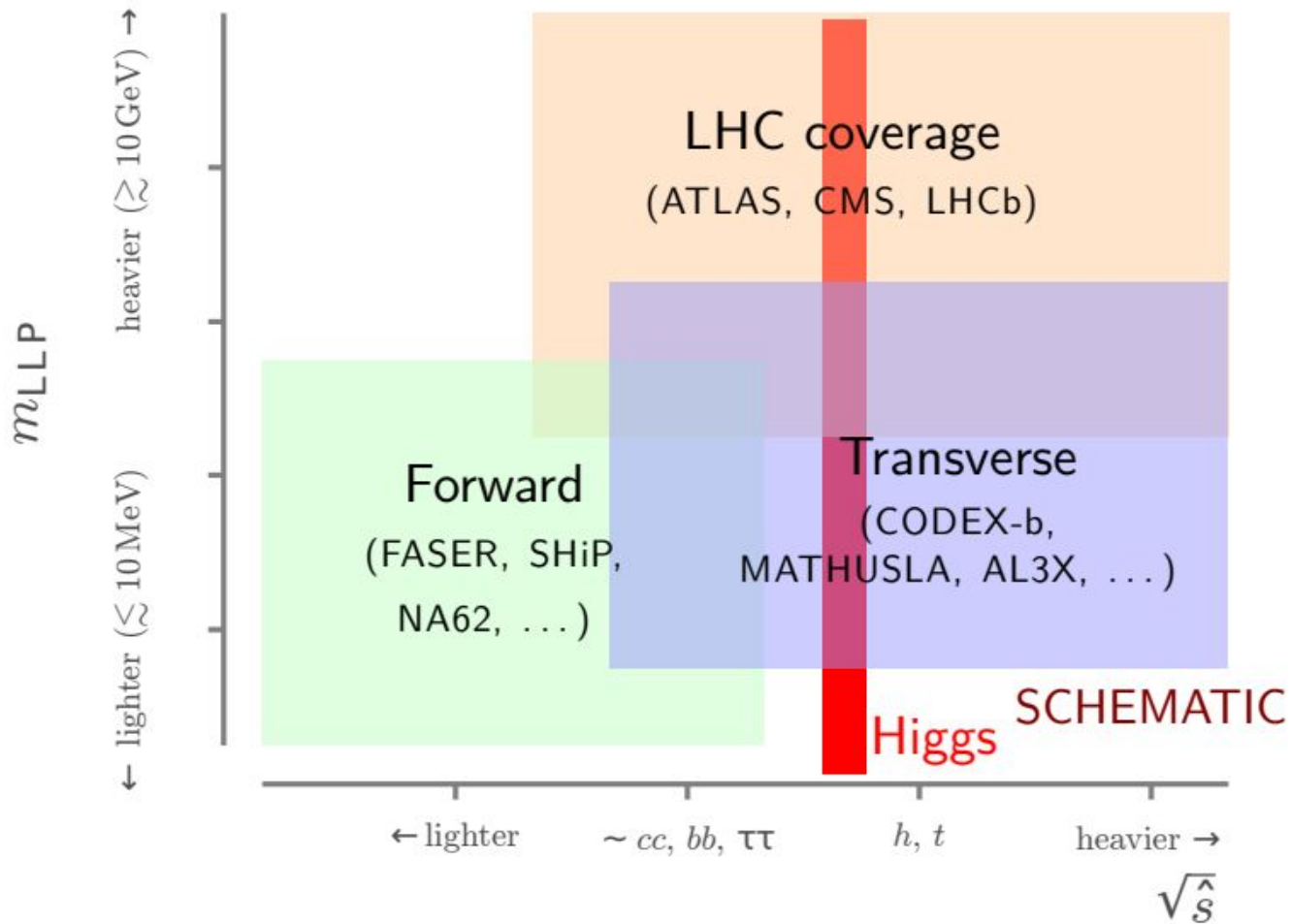

CODEX-b design

Forging a new detector



A COmpact Detector for EXotics at LHCb: CODEX-b

CODEX-b is a **10x10x10 m** cube, with hundreds of **Resistive Plate Chamber (RPC) detectors** assembled in triplets and mounted in mechanical frames.

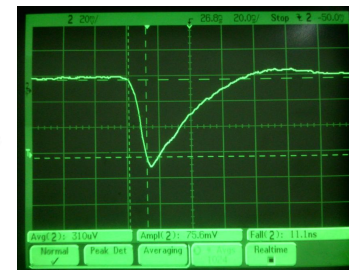
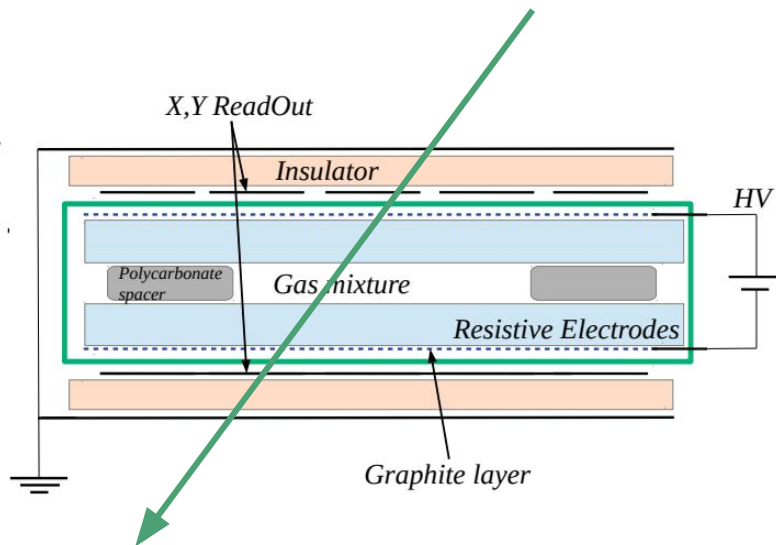
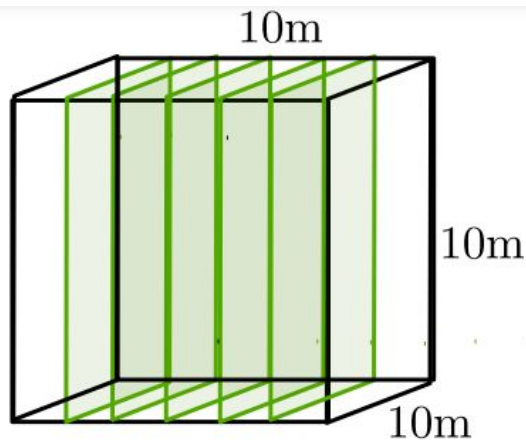

A tale of triplets and singlets

RPC singlets rely on BIS-78 technology (ATLAS muon upgrade).

RPC triplets (2 x 1 m) with 1 mm spatial resolution and 100 ps timing resolution.

More details later...

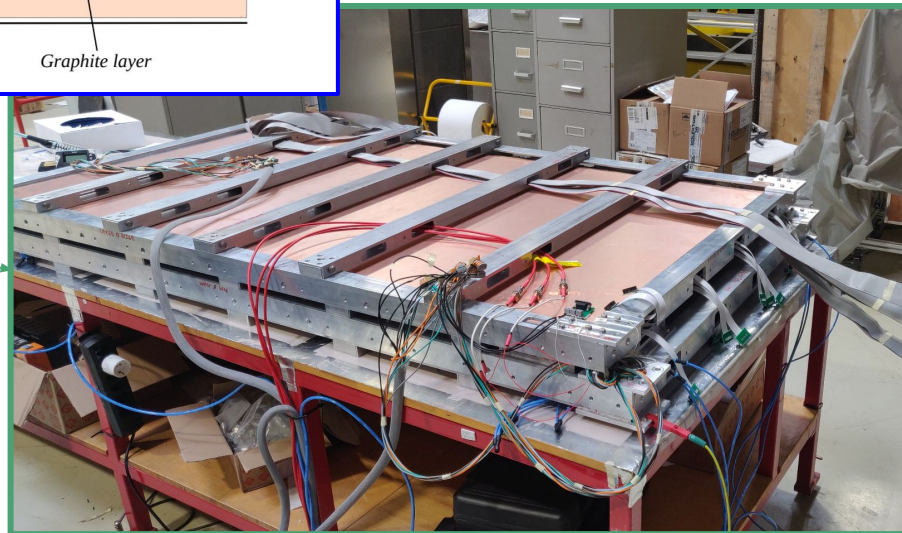
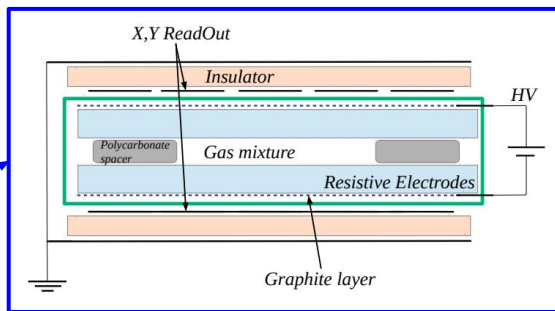

A background-free detector: shielding

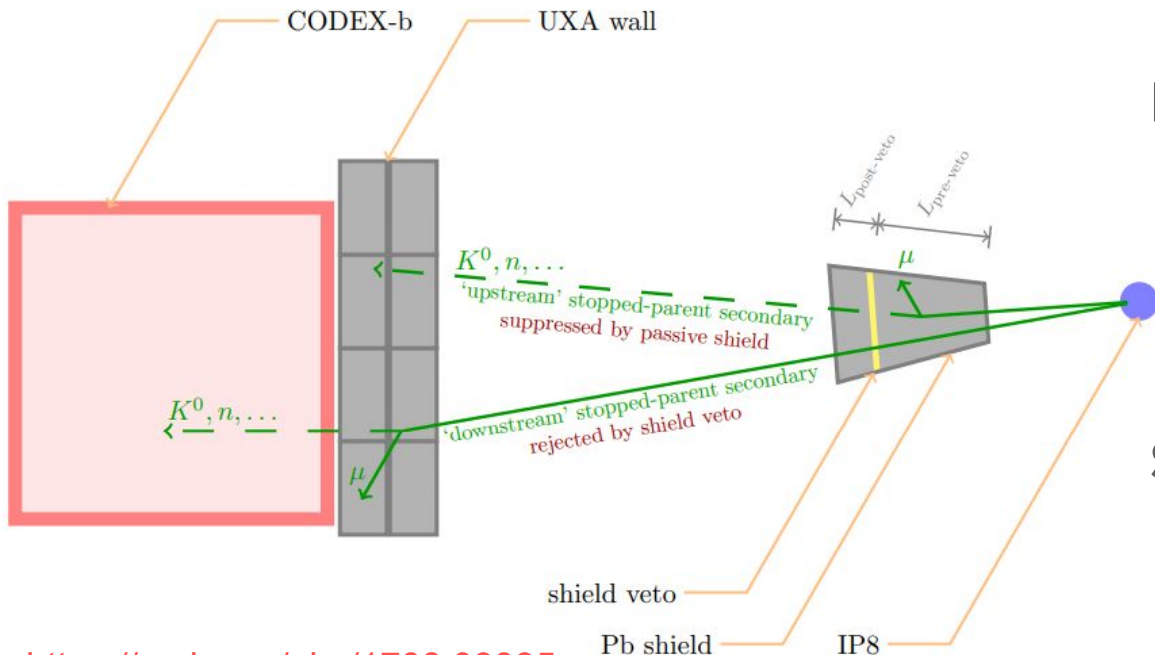

<https://arxiv.org/abs/1708.09395>
<https://arxiv.org/abs/1911.00481>

Expect 10^{14} neutrons and KL^0 in 300 fb^{-1} .

Main backgrounds:

- n, KL^0 (main) and μ ,
- penetrating the wall,
- or from secondaries or stopped-parent decays.

Shielding of $32\lambda/300 \text{ fb}^{-1}$:

- Pb shield (pre-veto) $\sim 20\lambda$,
- **Shield veto**,
- Pb shield (post-veto) $\sim 5\lambda$,
- UXA wall $\sim 7\lambda$.

Physics reach

Unveiling the undiscovered



An overview of minimal models

<https://arxiv.org/abs/1708.09395>

<https://arxiv.org/abs/1911.00481>

<https://arxiv.org/abs/2203.07316>

Vector (A')	$hA'A'$	$F'F$
$F'F$	yes	no reach
Scalar (S)	$SH^\dagger H$	$S^2H^\dagger H$
$SH^\dagger H$	yes	yes
HNL (N)	HLN	
HLN	yes	
ALP (a)	$\partial_\mu a \bar{q} \gamma^\mu \gamma^5 q$	$a \tilde{G} G$
	yes	yes

Production portal
 Decay portal
 UV operator

C. Minimal models

1. Abelian hidden sector
2. Scalar-Higgs portal
3. Axion-like particles
4. Heavy neutral leptons

(Only published studies)

Abelian hidden-sector: *dark photon*

Higgs to invisible (HL-LHC) limit
[arXiv:1902.00134](https://arxiv.org/abs/1902.00134)

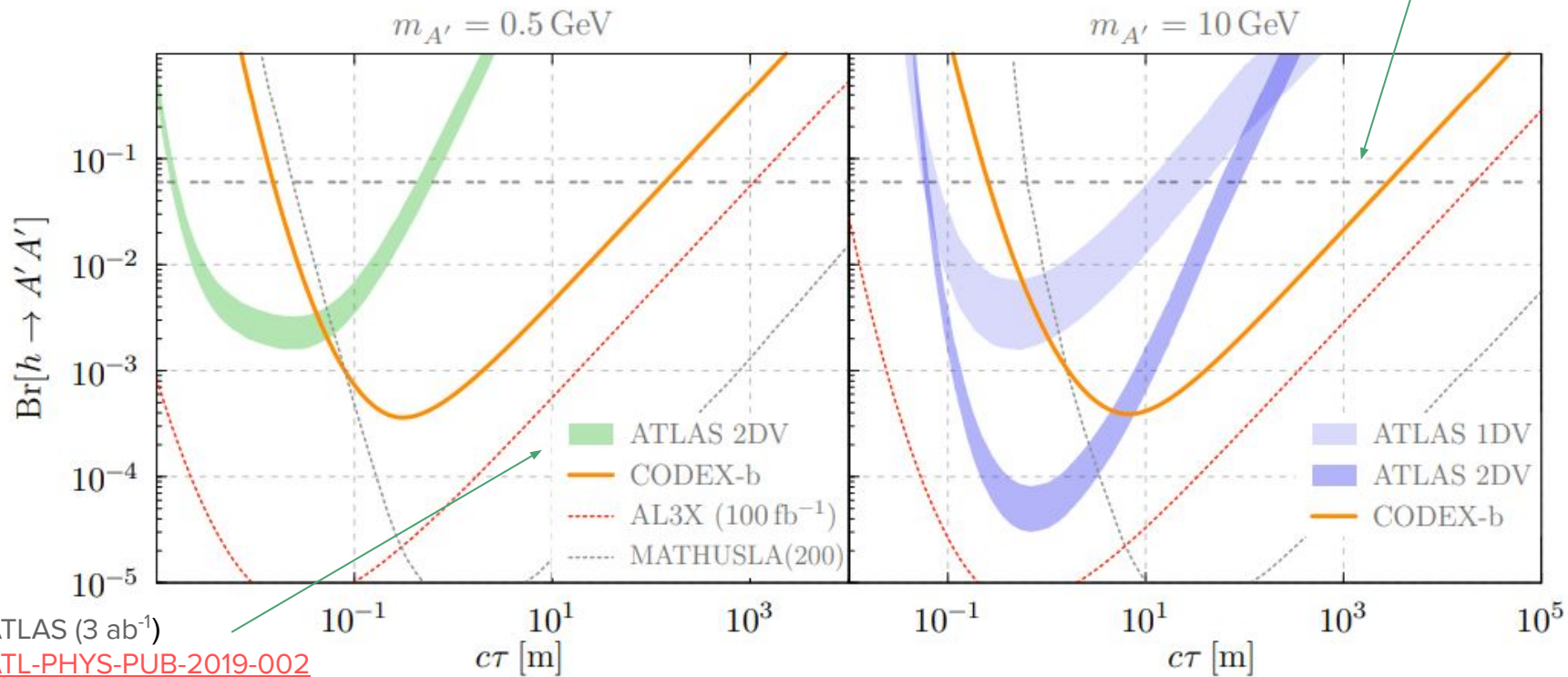

ATLAS (3 ab⁻¹)
[ATL-PHYS-PUB-2019-002](https://arxiv.org/abs/1902.00134)
[Phys. Rev. D 99, 052005](https://arxiv.org/abs/1902.00134)

Scalar-Higgs portal

$\lambda = 1.6 \times 10^{-3}$ From b-hadron decays

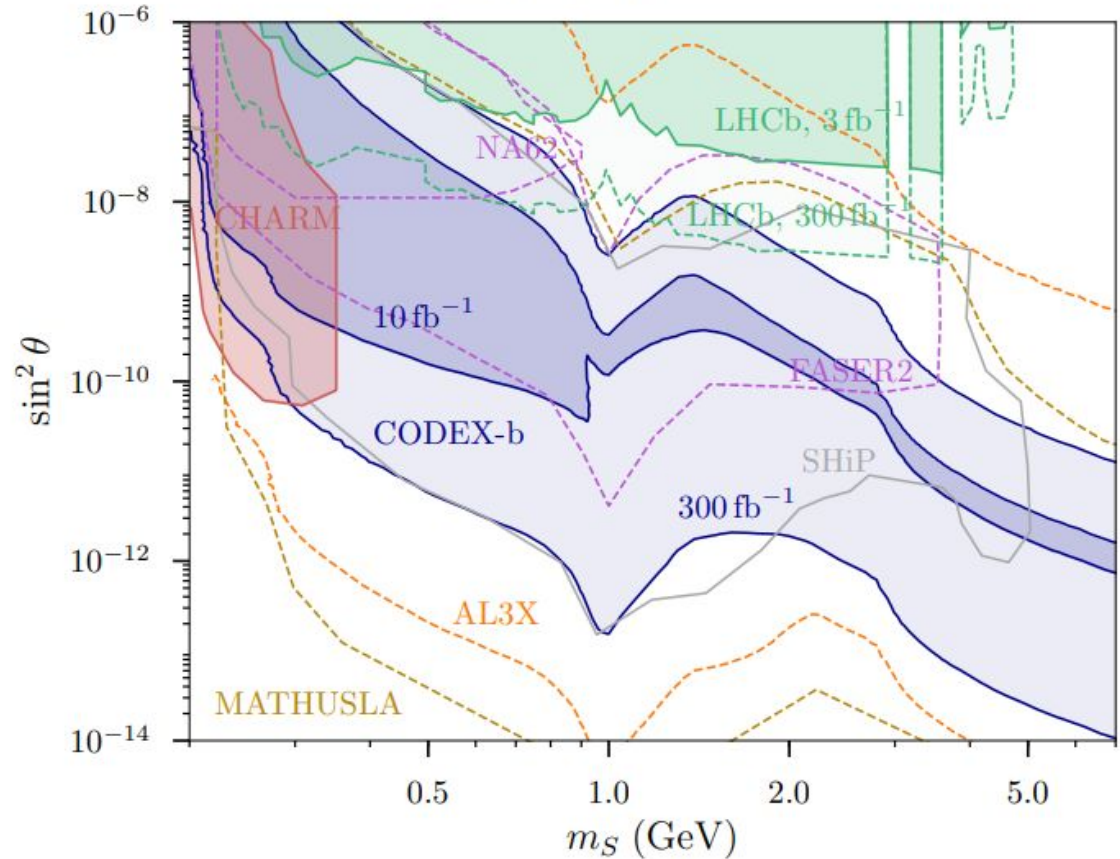
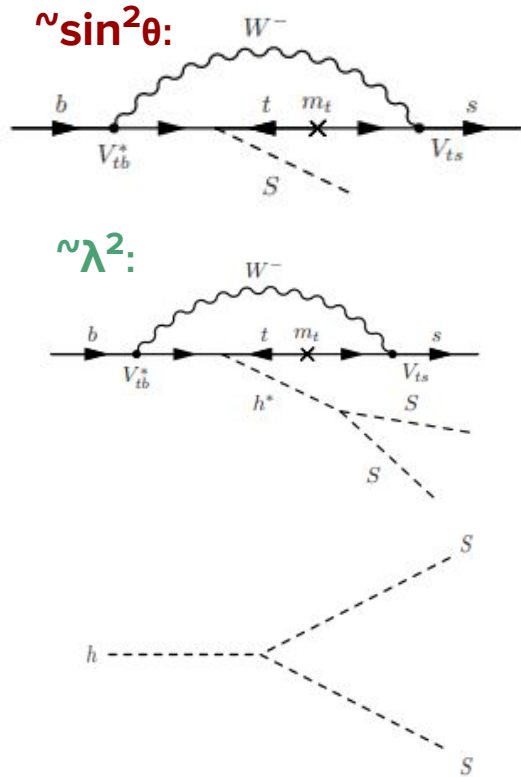

ALP w/ universal fermion couplings, $\Lambda=1\text{TeV}$

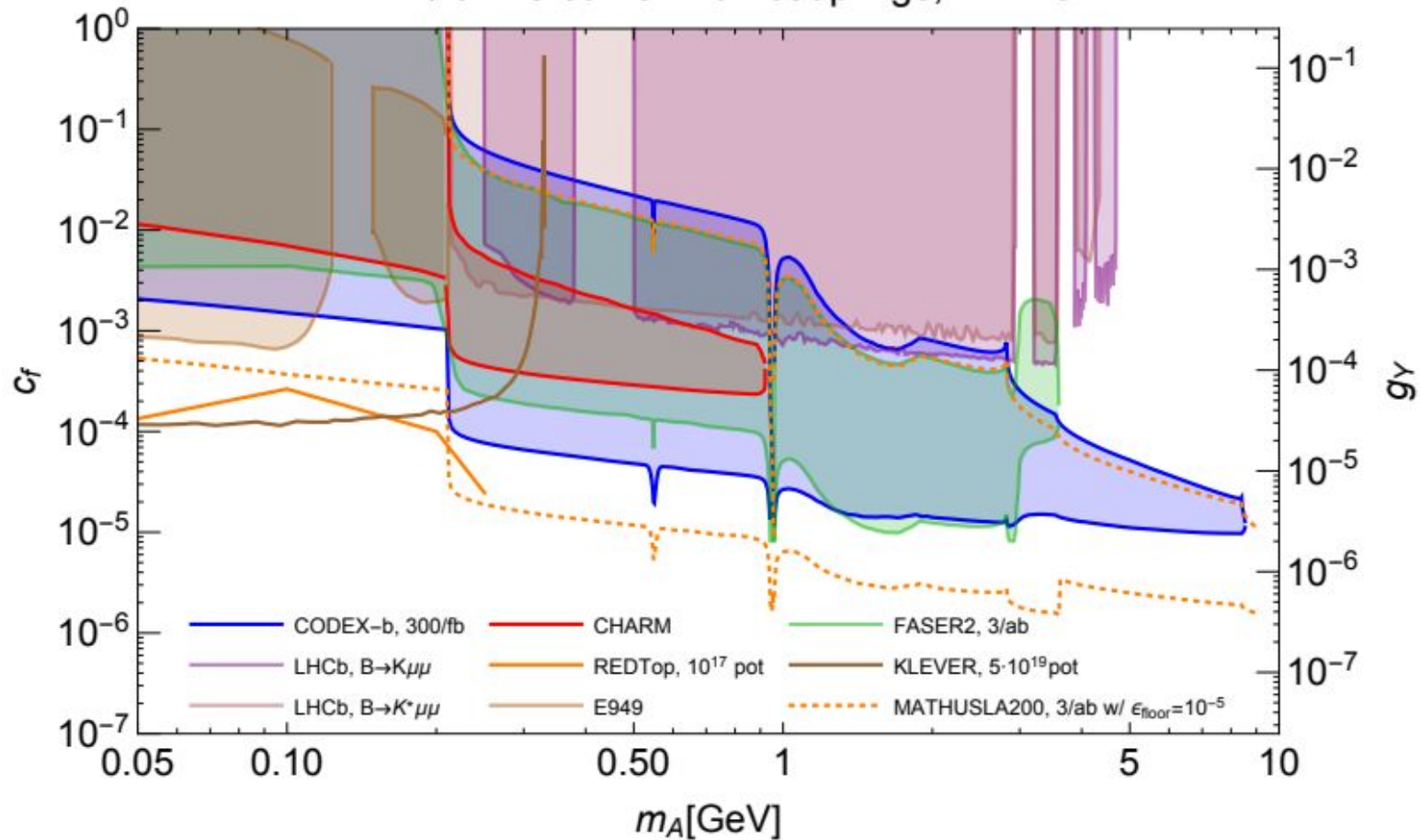

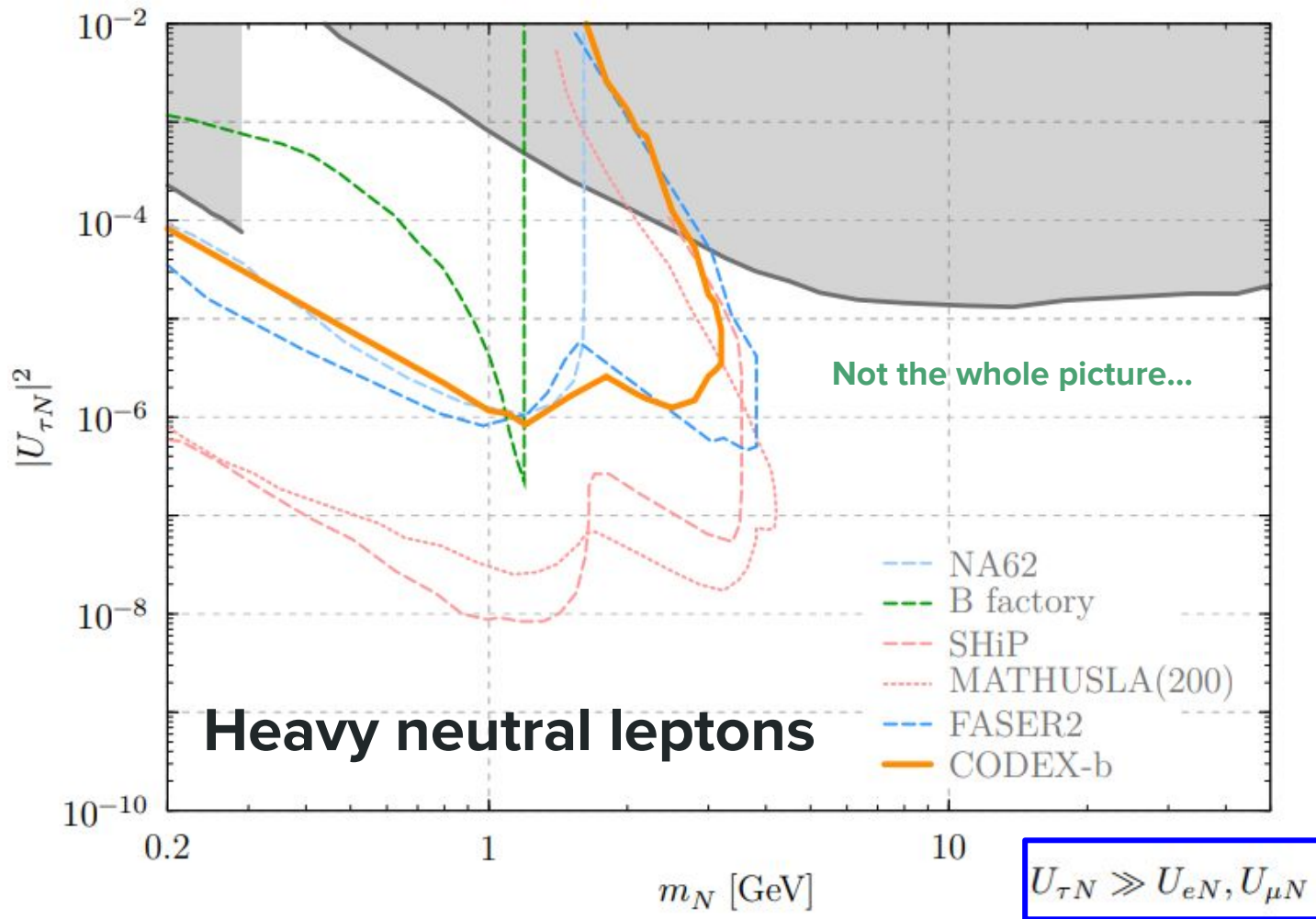

An overview of (minimal) models

<https://arxiv.org/abs/1911.00481>

Vector (A')	$hA'A'$	$F'F$						
$F'F$	yes	no reach						
	Scalar (S)	$SH^\dagger H$	$S^2H^\dagger H$					
	$SH^\dagger H$	yes	yes					
		HNL (N)	HLN					
		HLN	yes					
			ALP (a)	$\partial_\mu a \bar{q} \gamma^\mu \gamma^5 q$	$a \tilde{G} G$	$a \tilde{F} F$	$a(W\tilde{W} - B\tilde{B})$	
				yes	yes	pending	pending	

Production portal
 Decay portal
 UV operator

C. Minimal models

1. Abelian hidden sector
2. Scalar-Higgs portal
3. Axion-like particles
4. Heavy neutral leptons

D. Complete Models

1. R-parity violating supersymmetry
2. Relaxion models
3. Neutral naturalness
4. Inelastic dark matter
5. Dark matter cospattering
6. Dark matter from sterile coannihilation
7. Asymmetric dark matter
8. Other Dark Matter models
9. Baryogenesis
10. Hidden valleys

CODEX-β

CODEX-b β v0.1



The need for a demonstrator

New generation of LLP dedicated detectors have **one thing** in common: *they make use of conventional technology used in unconventional ways, e.g.*

- **Detector on the safe side of the LHCb cavern: CODEX-b,**
- **Detector in an access tunnel of the CMS cavern: milliQan,**
- **Detector in an installation shaft on the ATLAS cavern: ANUBIS...**

Various technical aspects need to be tested before spending O(10-100) M€ in a full experiment designed in *unconventional ways*.

The need for a demonstrator

CODEX-b will be a **O(10) M€**, near zero **SM-background detector**, composed by hundreds of **RPCs** arranged in a **10x10x10 m cube**.

Purpose of a demonstrator:

- Test the technology, design and integration with LHCb.
- **Measure the backgrounds accurately and validate our simulations,**
- **Perform physics measurements and update sensitivities projections.**

CODEX- β , a smaller version of CODEX-b, with **42 RPCs**, integrated with LHCb and taking data during Run 3 (2025), costing **$\sim 1\%$** of the full CODEX-b detector.

Designing the origins

CODEX- β is a 2 x 2 x 2 m cube:

- Each side is composed by 2 panels, 1 x 2 m each $\rightarrow 2 \times 6 = 12$ panels,
- 2 panels inside $\rightarrow 12 + 2 = 14$ total panels.
- Each panel consists of a RPC triplet (3 singlets),
- Design from BIS78 ATLAS upgrade project (as for CODEX-b).

Mechanical frames completely redesigned by the CODEX-b team, built in the UC workshop.

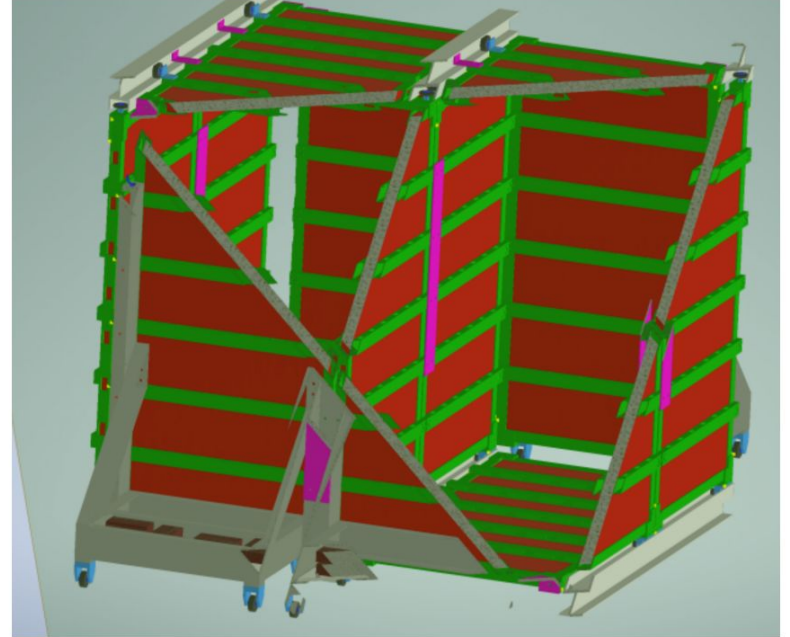

Assembling and testing the RPCs

Target: assemble **14 panels**, with a RPC triplet each → **42 RPC singlets**.

Today: built **22 of 42 singlets**, starting triplet characterization.

Began at BB5, but space needed by ATLAS start of 2024.

Migrated to B904 site, adjacent to CMS RPC workspace:

- Gas from CMS RPCs,
- Electronics and grounding ready to go,
- Trigger boards arrived and fully functional.

**Huge thanks to ATLAS,
CMS and ANUBIS!** 🙌

**Plan to complete installation
and commissioning this year,
and start the data-taking
campaign by 2025.**

Assembling and testing the RPC

Target: assemble 14 panels, with a RPC triplet

Today: built 22 of 43

Began at BB5, but sp

Migrated to B904 sit

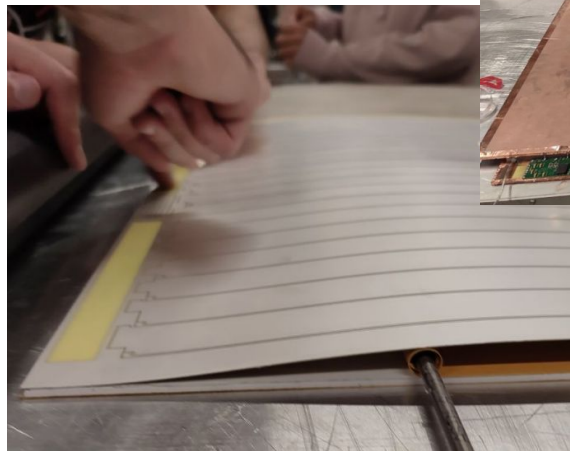

o ATLAS,
UBIS! 🙌

an to complete installation
d commissioning this year,
and start the data-taking
campaign by 2025.

Assembling and testing the RPC

Target
Today
Begin
Might

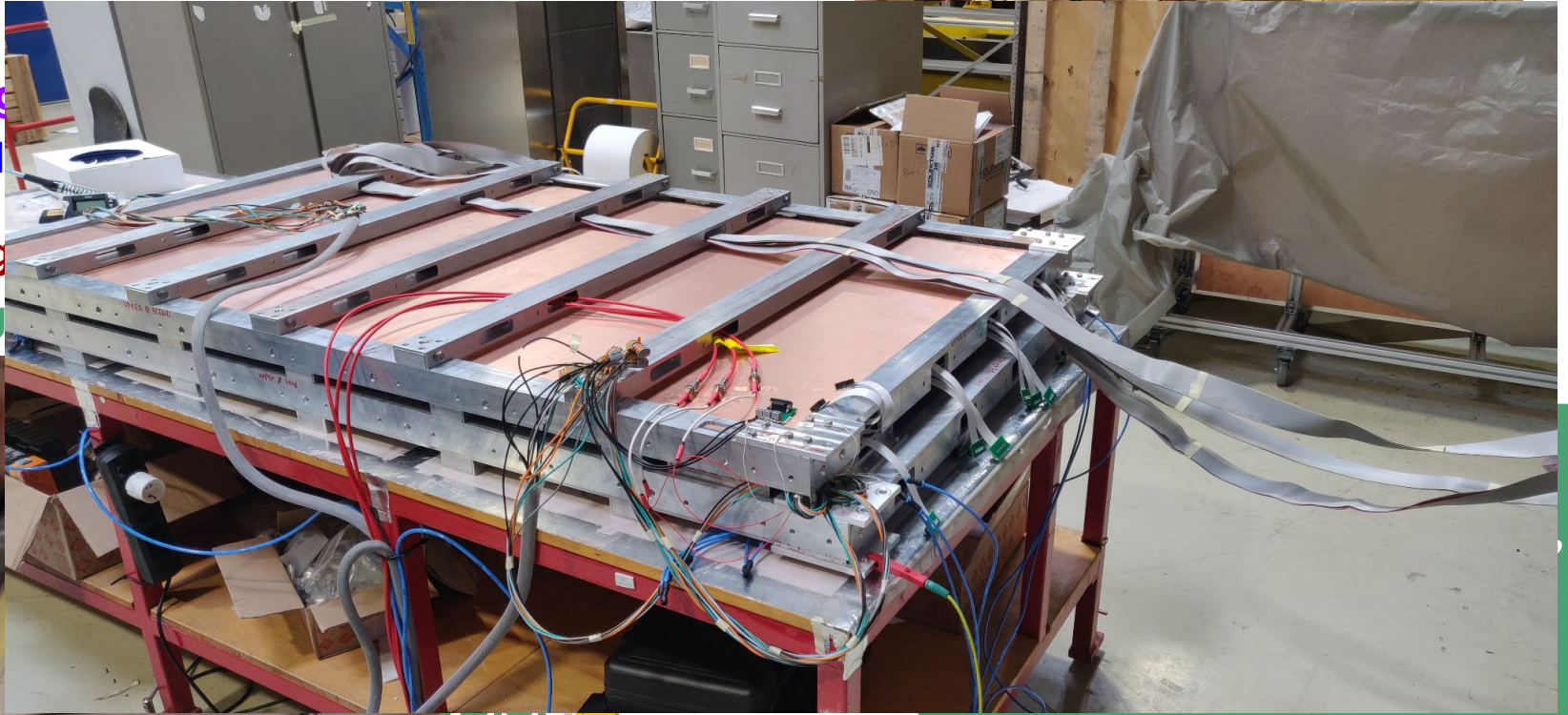

Assemb

Target
Today

Begin
Mig



Assembling and testing the RPCs

Target:

Today:

Began:

Migrating:

> Gas

> Elec

> Trigg

Technical design report for the CODEX- β demonstrator

Coming **TOMORROW** to the arXiv! Stay tuned!
(preview version attached to the indico)

A similar document on the **physics plan with CODEX- β** will be released as well in the next months!

Huge thanks to **ATLAS,**
CMS and **ANUBIS!** 🙌

and start the data-taking
campaign by 2025.

Preparing the D1 barracks

D1 barracks are empty now, power supply available.

Working now on:

- **Providing a gas line for RPCs,**
- Preparing the safety procedure for working in D1.
- Transport from B904 to P8 (300 kg/frame), use of PZ lift.

Gas system:

- **Mixer + recirculation system ordered and underway.**
- **GHG emissions not scalable for CODEX-b → R&D in search for an ecomixture.**

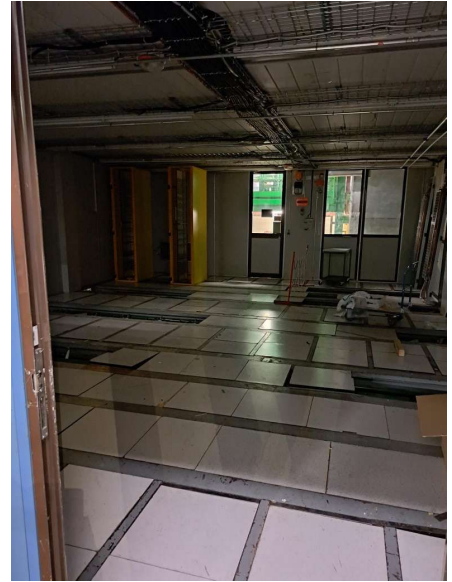

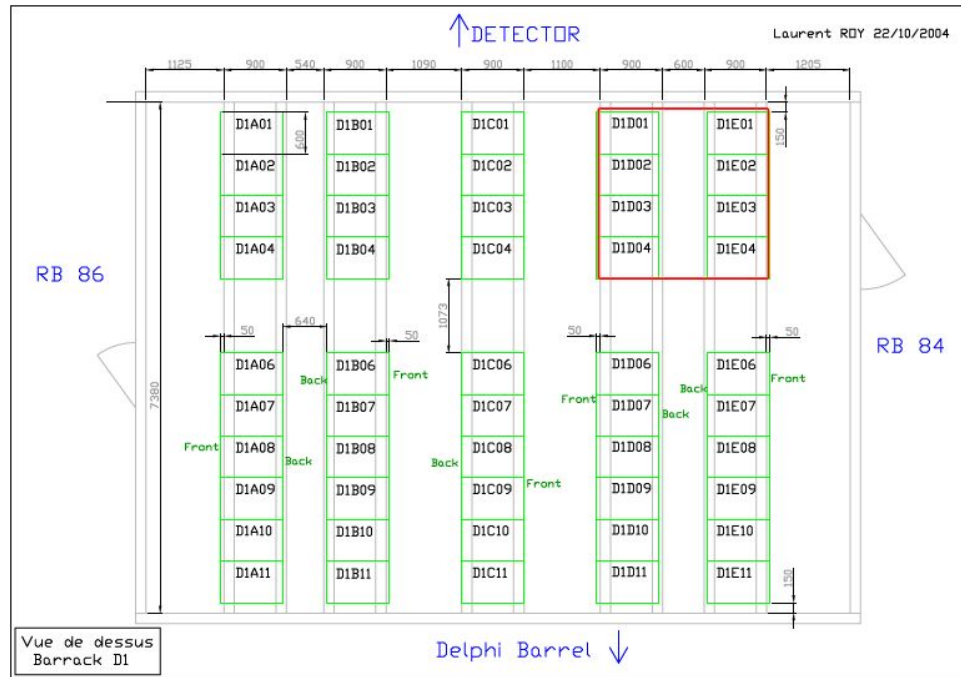
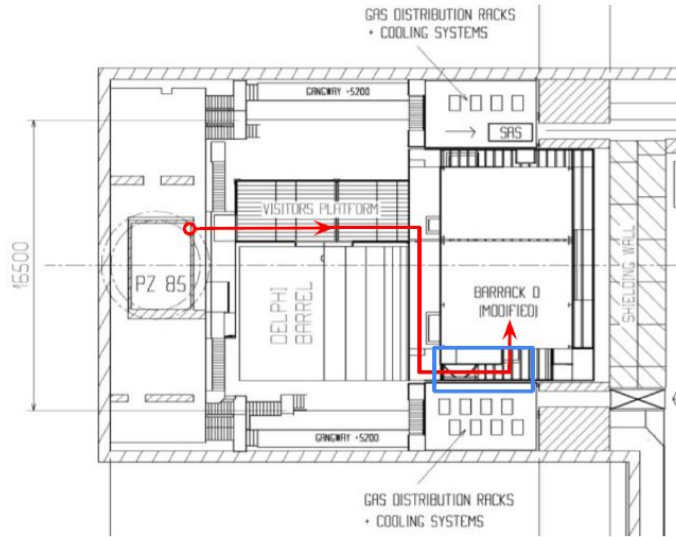

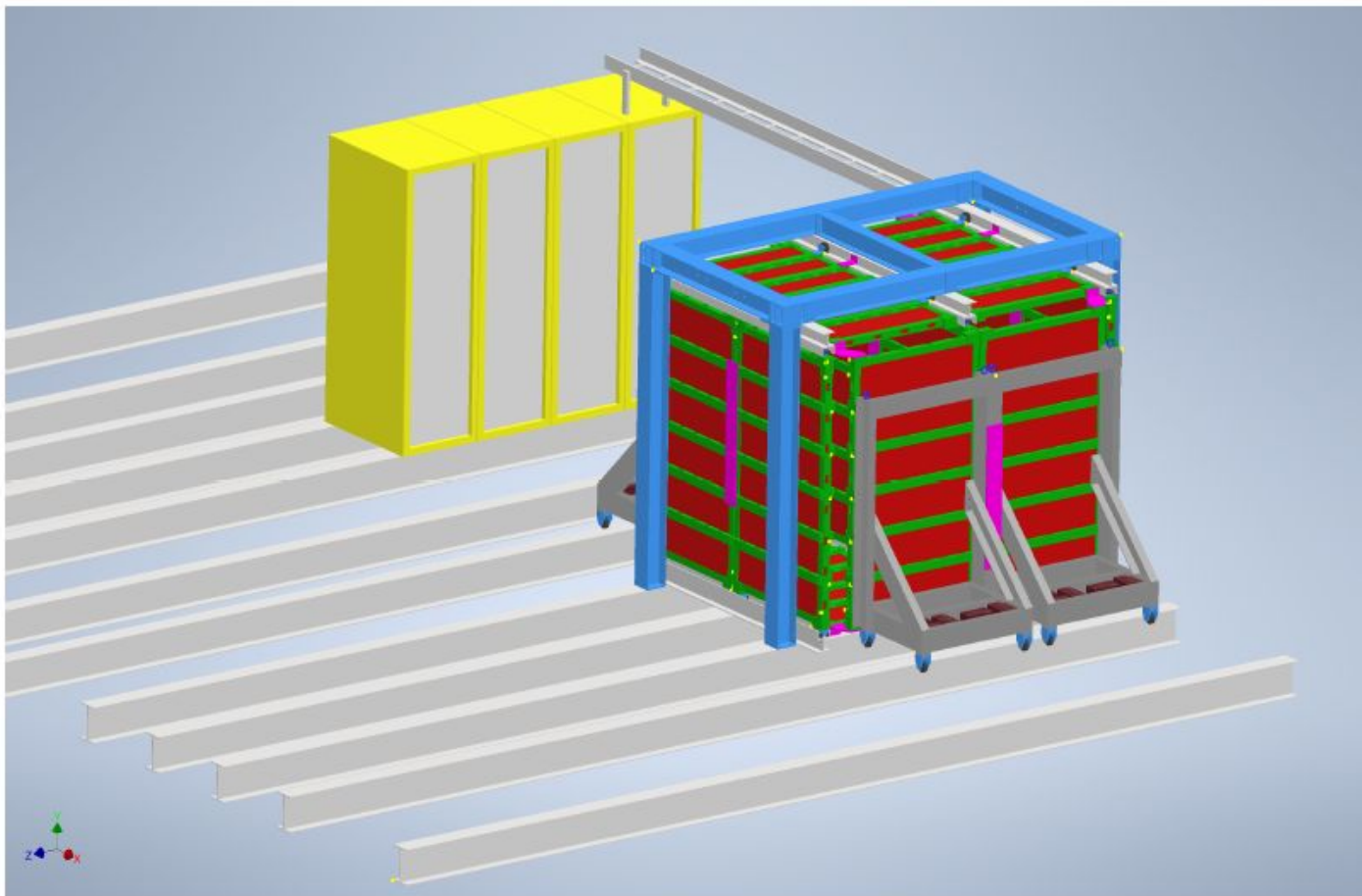
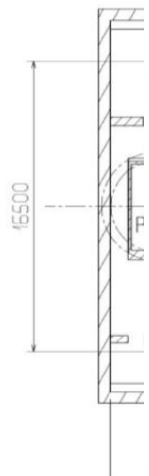

22/10/2004

RB 84

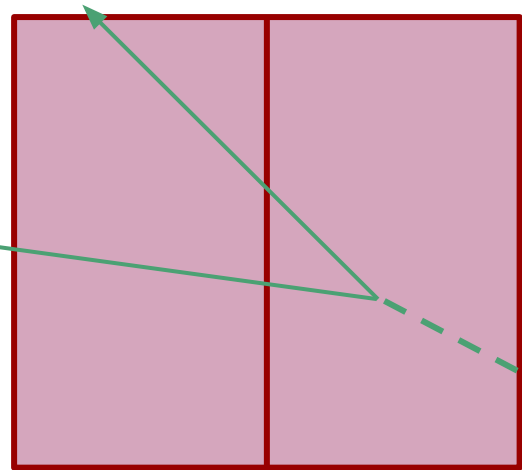

CODEX- β

"D1" experiment location

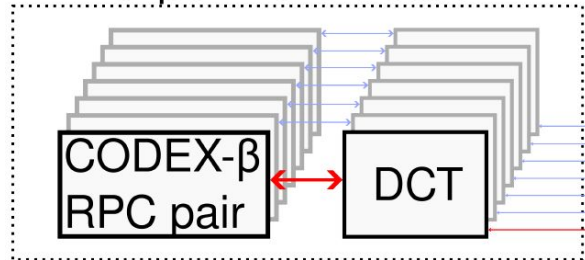

LHCb

Surface event-builder farm

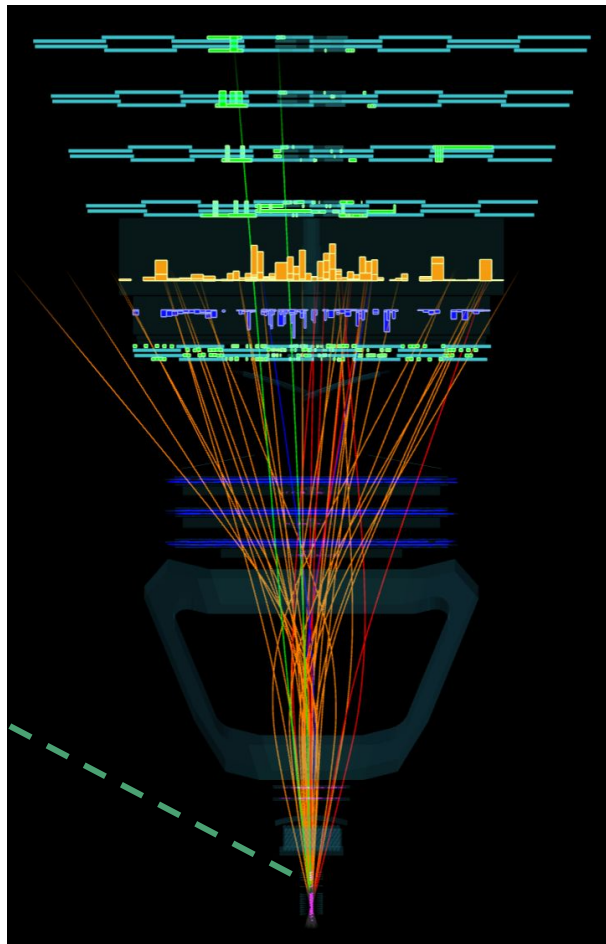
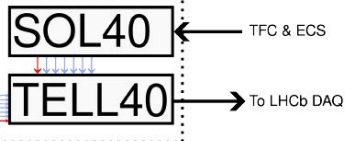

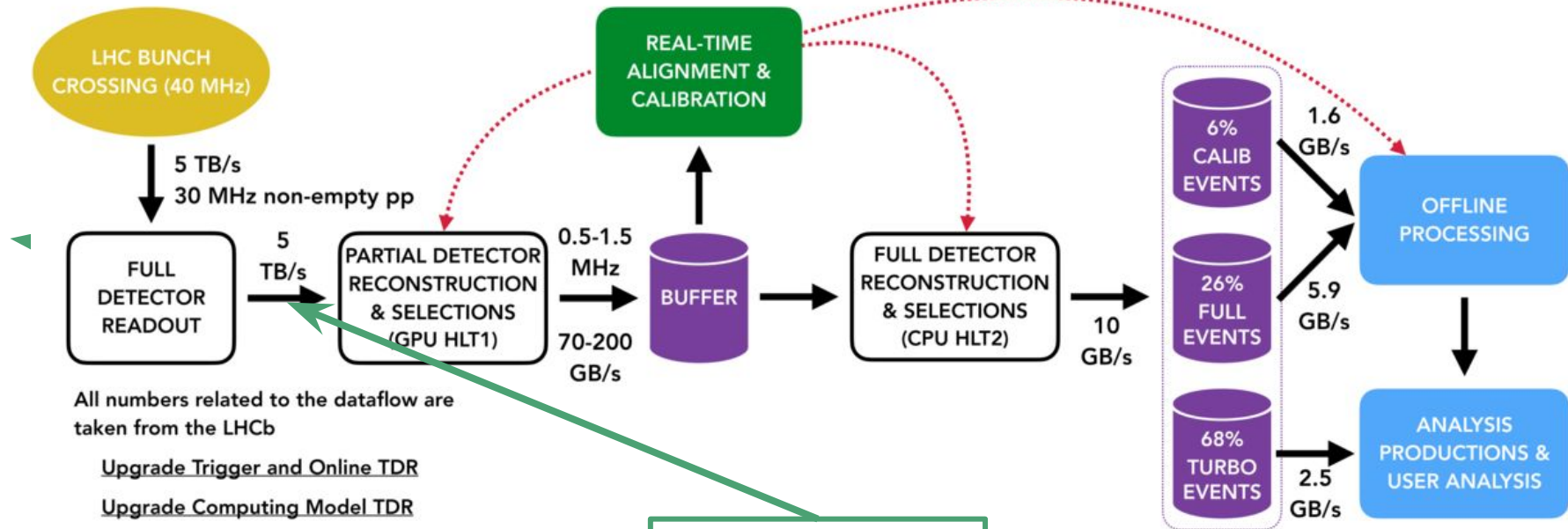

"D1" experiment location

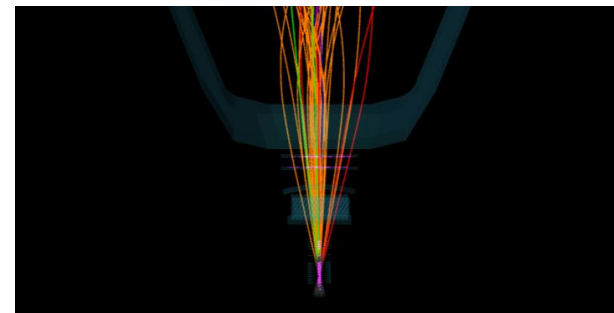
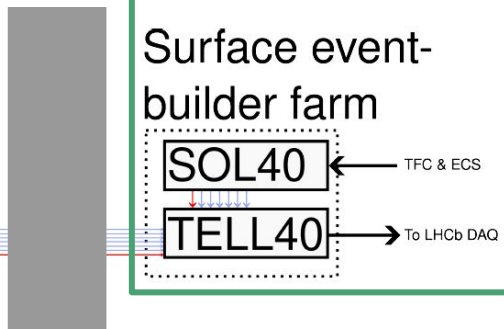
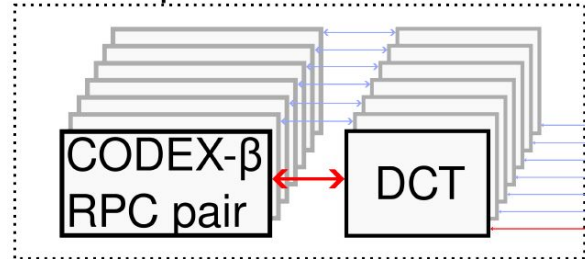

LHC BUNCH
CROSSING (40 MHz)

REAL-TIME
ALIGNMENT &
CALIBRATION

1.6

- RPCs readout by DCTs (Data Collection & Transmission).
- DCT readout design being finalized by ATLAS experts.
- Control, communication, and synchronisation with LHCb are challenging → need for FPGA expertise to make DCT readout LHCb-compatible.
- Additional data bank to the LHCb Hlt → negligible data size.

NE
SING

SIS
ONS &
ALYSIS

"D1" €

CODEX-p
RPC pair

DCT

TELL40

To LHCb DAQ

Summary





growing team with 22 institutes with 53 members
 theory (5), engineering (4), ATLAS (10), CMS (5), LHCb (29)
 leadership from all 5 categories <https://codex-b.web.cern.ch/>

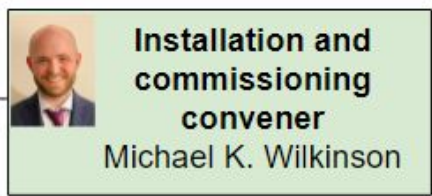
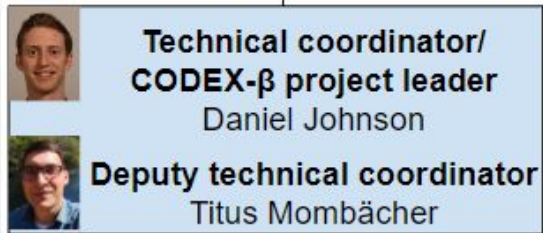
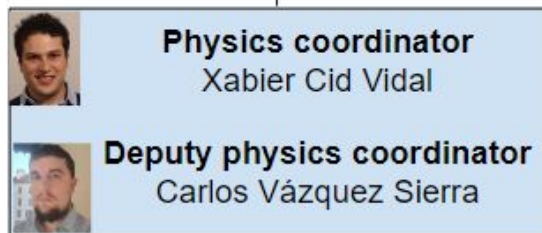
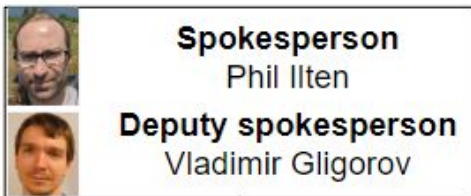

Summary

- **Intense and fruitful year for the CODEX-b team (and for everyone).**
- **Finalize the construction and installation of CODEX- β by 2024.**
- Take data by the end of 2024/beginning of 2025.
- **Challenges ahead:** DAQ/readout design, LHCb integration.
- **Collaboration in a healthy status** \rightarrow **10 talks in 2023 (EPS, LLP13, Higgs...), 2 talks in 2024 plus 1 poster and 2 secured talks (LHCP @ Boston, LLP14 @ Tokyo).**

However, we would benefit from personpower to cover specific gaps we need to reinforce (see above), if you would like to join us let us know!



Here are the Victorian-era particle physicist images you requested, capturing the moment of discovering dark matter in CODEX-b. If you need any adjustments or additional elements, feel free to let me know!

Thank you! Questions? Lunch?

Backup

Reinterpretation with Delphes

• MDS detector response is calorimetric

- Only depends on generator-level LLP hadronic energy, EM energy, and decay positions → release parameterized functions as supplementary materials on [HEPData](#)
- Integrated the CSC cluster detector response functions to Delphes: <https://github.com/delphes/delphes/pull/103>
- Recasted the analysis and projected sensitivity in a number of models: dark scalar, dark photon, ALPs, inelastic DM, hidden valley models, HNL, and VLL
 - These recasting efforts inspired the ongoing CMS analyses mentioned earlier

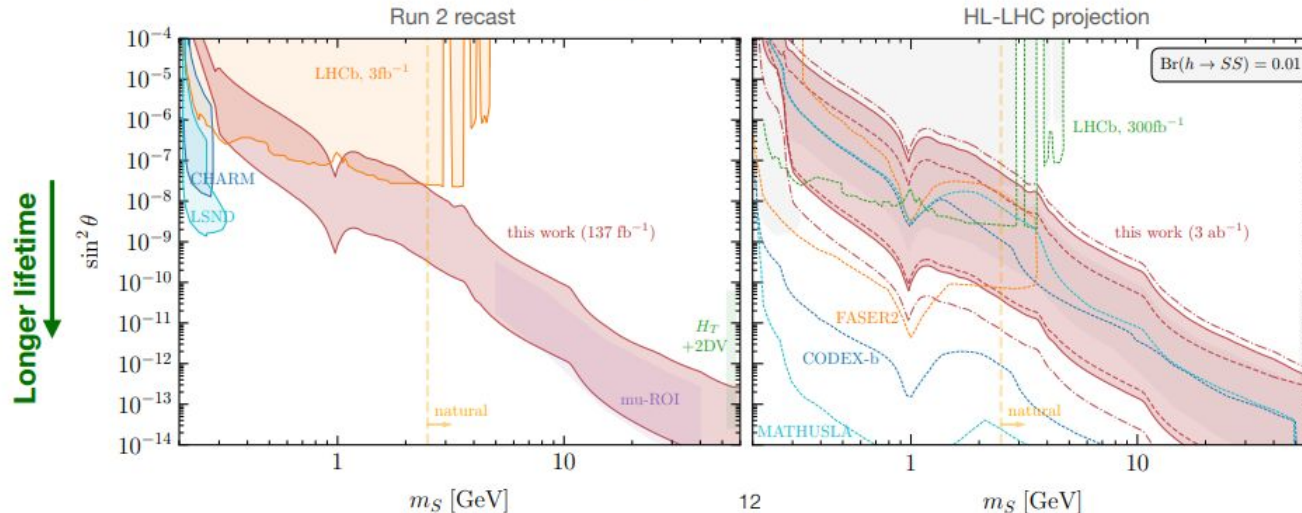

Dark scalar model

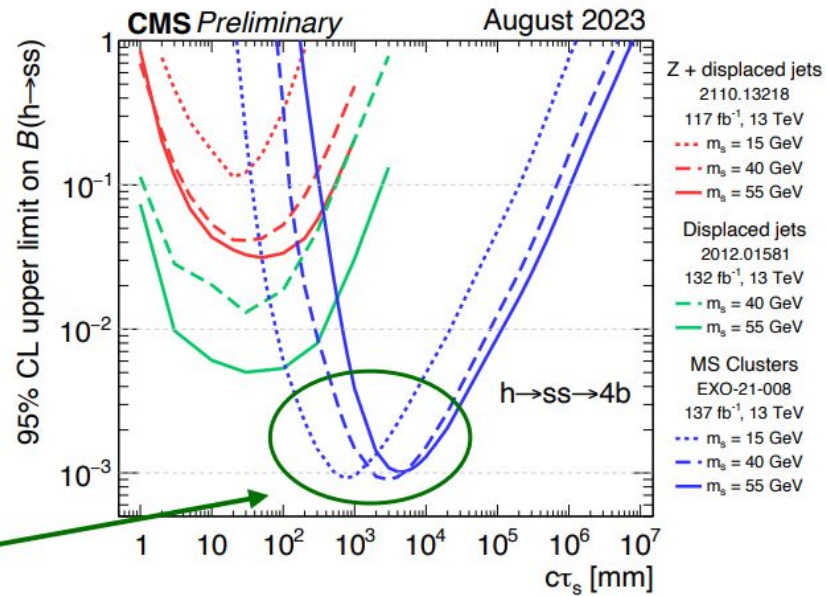
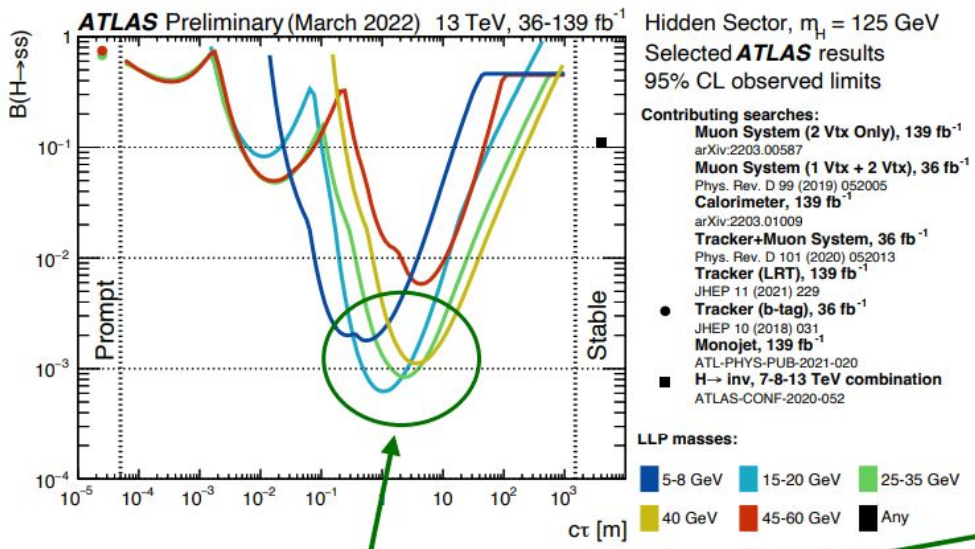

- Muon system analyses are among the most sensitive searches for both ATLAS and CMS

A background-free detector: shielding

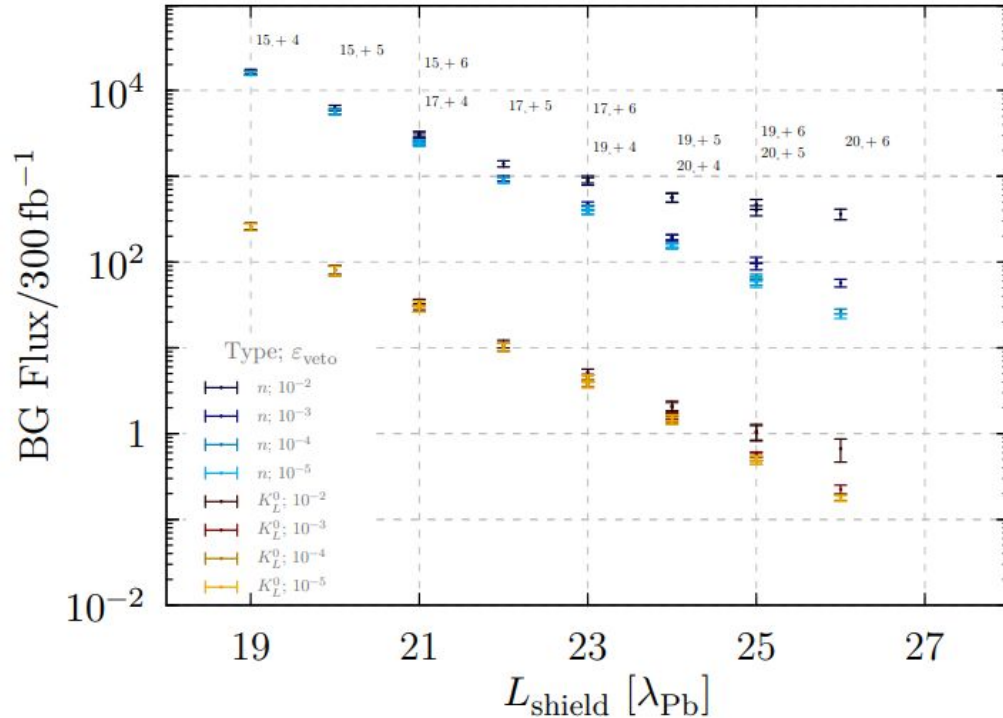

Measurement campaign of backgrounds in D1 barracks during 2018.

<https://arxiv.org/abs/1912.03846>

Detailed simulations with Pythia, consistent with FLUKA predictions by CERN Radiation Protection.

An overview of minimal models

<https://arxiv.org/abs/1708.09395>

<https://arxiv.org/abs/1911.00481>

<https://arxiv.org/abs/2203.07316>

Vector (A')	$hA'A'$	$F'F$						
$F'F$	yes	no reach						
	Scalar (S)	$SH^\dagger H$	$S^2H^\dagger H$					
	$SH^\dagger H$	yes	yes					
		HNL (N)	HLN					
		HLN	yes					
			ALP (a)	$\partial_\mu a \bar{q} \gamma^\mu \gamma^5 q$	$a \tilde{G}G$	$a \tilde{F}F$	$a(W\tilde{W} - B\tilde{B})$	
				yes	yes	pending	pending	

 Production portal
 Decay portal
 UV operator

C. Minimal models

1. Abelian hidden sector
2. Scalar-Higgs portal
3. Axion-like particles
4. Heavy neutral leptons

Physics with CODEX- β : Background studies

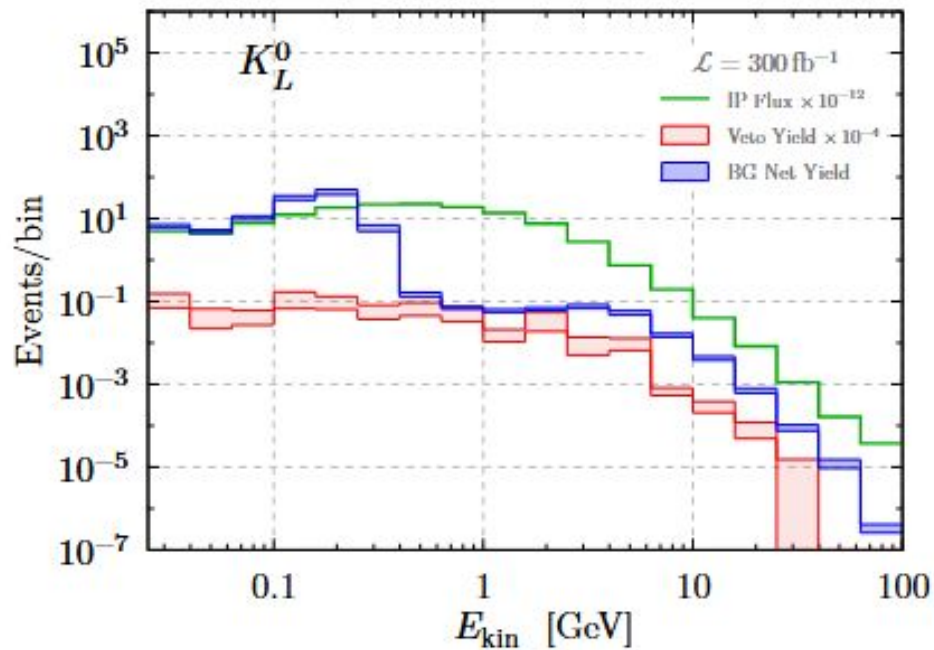
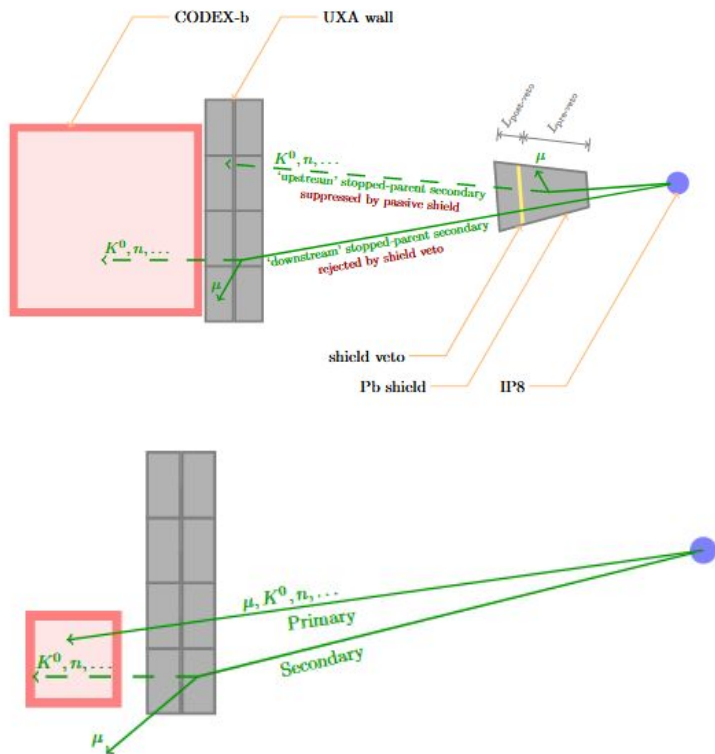

Physics with CODEX- β : Trial NP analysis

Tracks	Total	K_L^0 contribution
1	$(3.9 \pm 0.1) \times 10^8$	$(2.9 \pm 0.1) \times 10^8$
2	$(4.1 \pm 0.1) \times 10^7$	$(3.7 \pm 0.1) \times 10^7$
3	$(6 \pm 1) \times 10^5$	$(2.9 \pm 0.4) \times 10^5$
4+	$(9 \pm 2) \times 10^4$	$(7 \pm 2) \times 10^4$

- **Example:** χudd interaction, $\chi \rightarrow 4h$ decay
(Motivated by baryogenesis scenario)

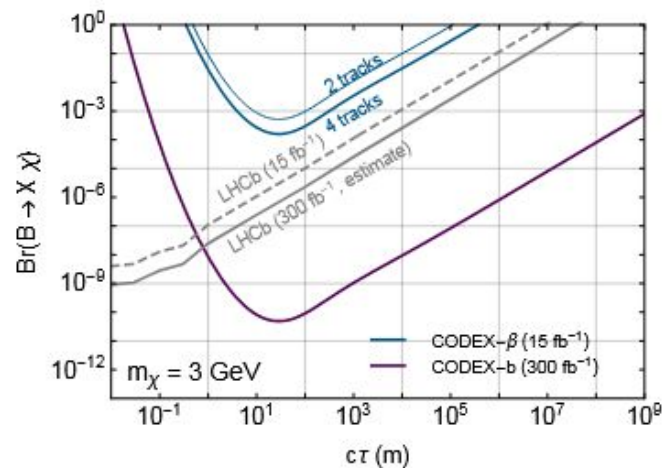

Physics with CODEX- β : K_S^0 lifetime measurement

GEANT4-based sim

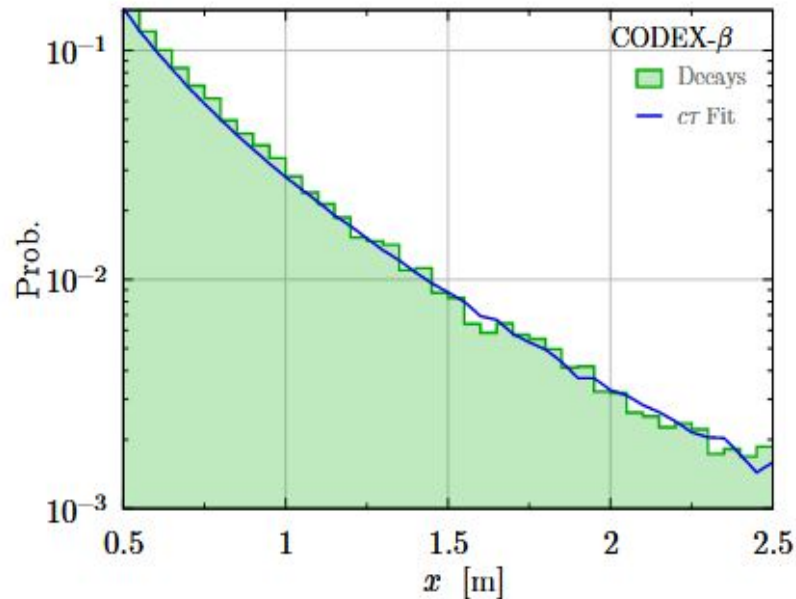
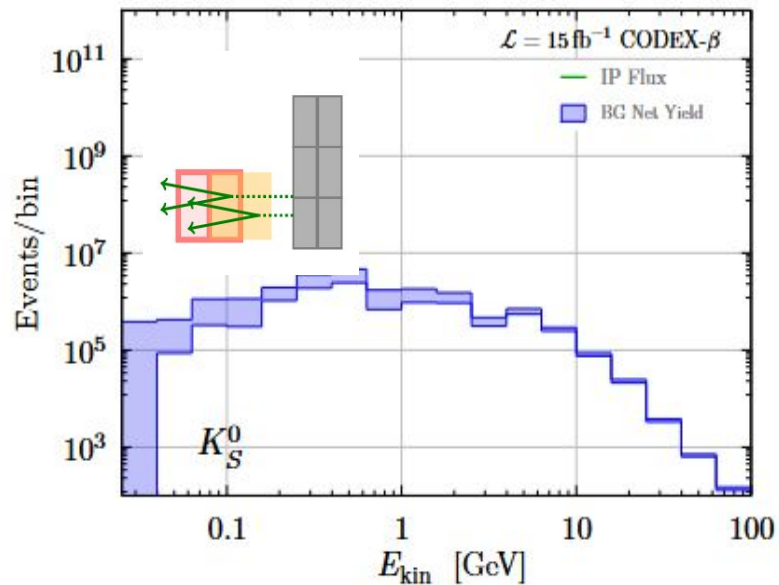

Simulation and reconstruction software

We had some hackathons during our first CODEX-b week:

Simulation:

Implementations in Detector and Gauss. **Still need to validate CODEX- β geometry, and write the digitalisation in Boole.**

Reconstruction:

Prepare simulation samples \rightarrow set of tracks for physics analyses, and obtain quantities of interest from these. **Still in early phase.**

These are the first steps towards developing a full analysis framework embedded in the LHCb software stack.

Transporting the frames to the barracks

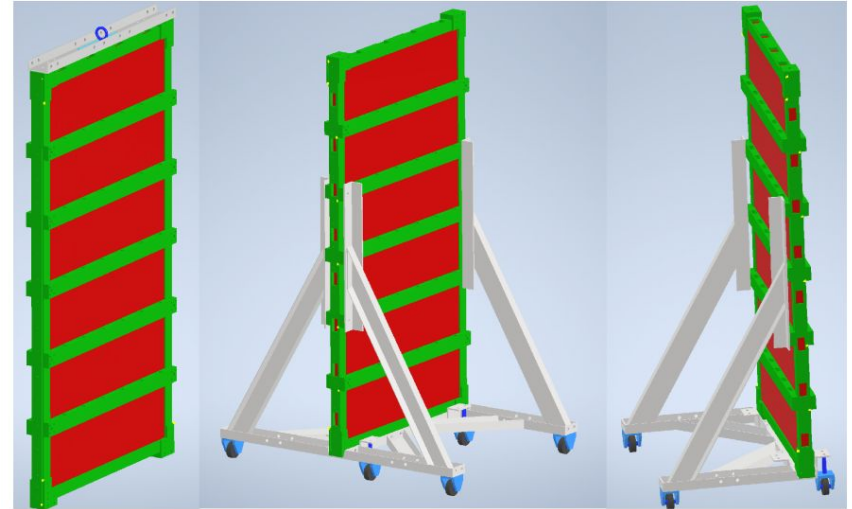
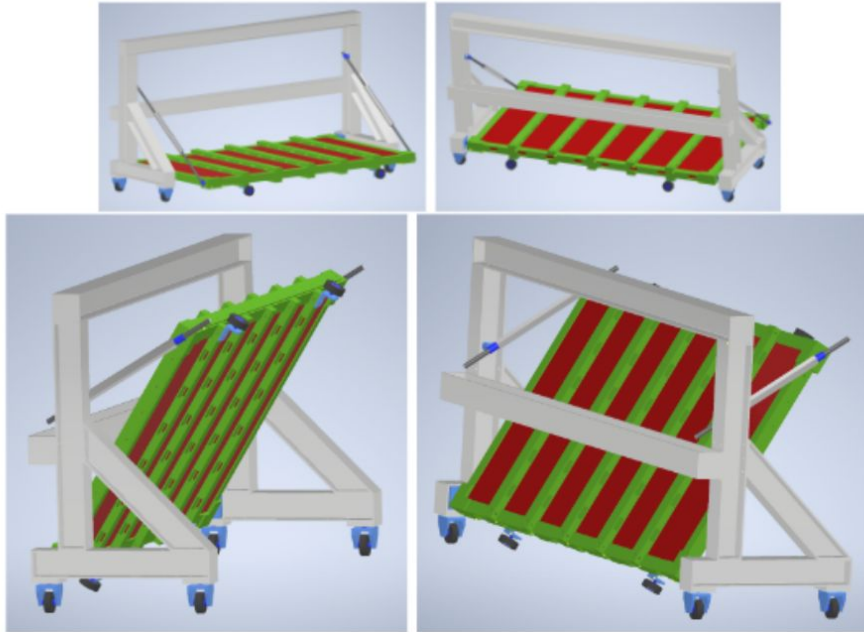

Moving the frames to D1 barracks.

Transporting the frames to the barracks

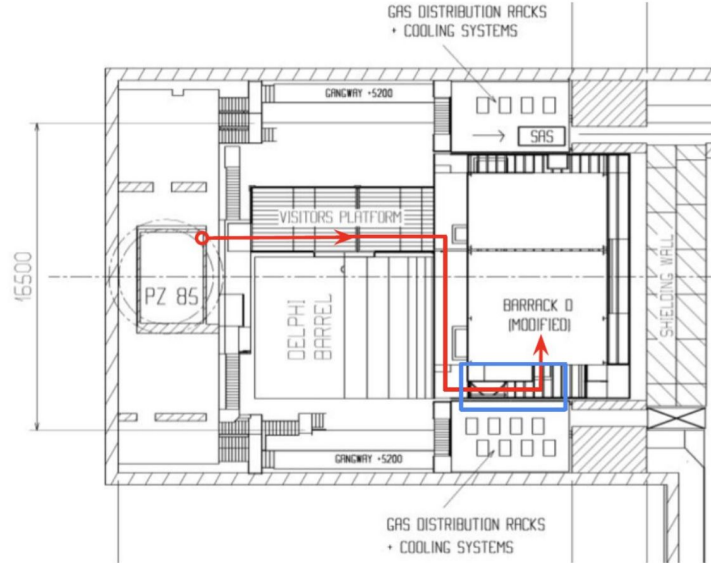

- Shipped from B904 to P8.
 - Weight per triplet inc. cart \sim 300 kg.
- Transported with PZ lift.**

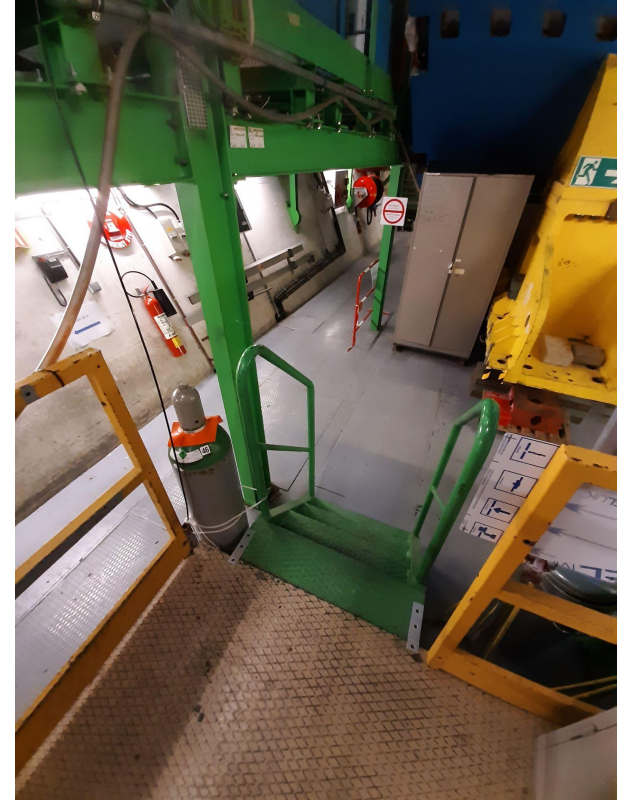

Assembling CODEX- β

- Cubic, aluminium structure + 2 racks
- Consists of I-beams, C-channels, and angles, bolted in situ
- 12 chambers mounted on structure; 2 roll-up
- Load on the structure from the two chambers on the top face
- Support structure development closely followed by CERN HSE

Once assembled, test the chambers:
repeat all RPC testing after installation,
plus cosmics, powering, etc.

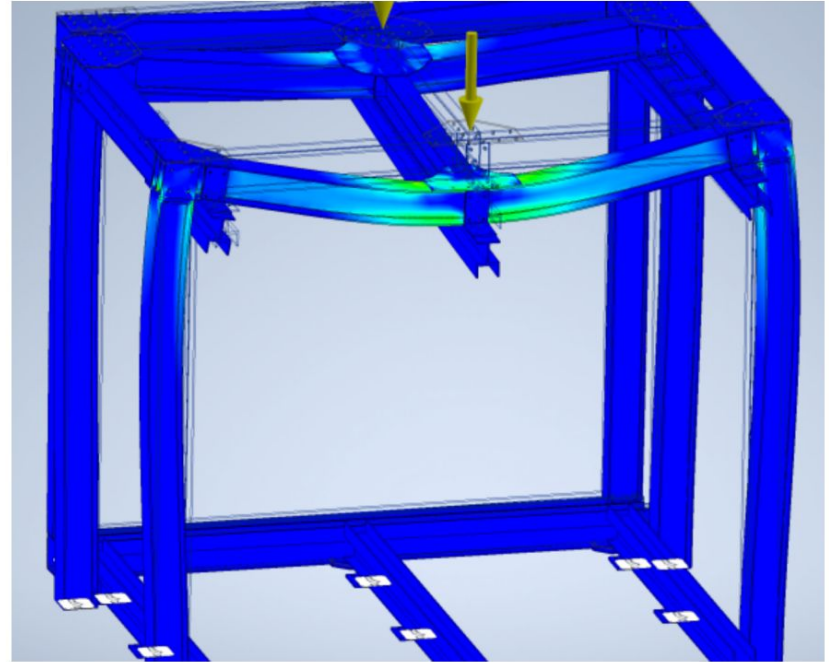

(exaggerated FEA - actual deflection \varnothing (1)mm)

Assembling and testing the RPCs

Target: assemble **14 panels**, with a RPC triplet each → **42 RPC singlets**.

Assemble one RPC singlet: prepare the **panels**, attach **readout cards** (solder LV and readout connections), **add the gas gap** and **close the Faraday cage**.

Test that one RPC singlet: test **each resistor** in the panels, the **LV**, the **readout**, the **Faraday cage**, an **IV test** with external power supply, and a **gas** and **HV leak** test.

Coverage mockup plots

1. ATLAS & CMS: Heavy LLPs ($m_{\text{LLP}} \gtrsim 10 \text{ GeV}$) for all lifetimes ($c\tau \lesssim 10^7 \text{ m}$).
2. LHCb: Short to medium lifetimes ($c\tau \lesssim 1 \text{ m}$) for light LLPs ($0.1 \text{ GeV} \lesssim m_{\text{LLP}} \lesssim 10 \text{ GeV}$).
3. Forward/beam dump detectors (FASER, NA62, SHiP): Medium to long lifetime regime ($0.1 \lesssim c\tau \lesssim 10^7 \text{ m}$) for light LLPs ($m_{\text{LLP}} \lesssim \text{few GeV}$), for low $\sqrt{\hat{s}}$ production channels.
4. Shielded, transversely displaced detectors (MATHUSLA, CODEX-b, AL3X): Relatively light LLPs² ($m_{\text{LLP}} \lesssim 10\text{--}100 \text{ GeV}$) in the long lifetime regime ($1 \lesssim c\tau \lesssim 10^7 \text{ m}$), and high $\sqrt{\hat{s}}$ production channels.

Backgrounds in CODEX-b

- **Main backgrounds:**

- μ (primary or secondary) that can penetrate concrete+Pb shield
- $n/\pi^\pm/K^\pm/K_L^0$

- **Additional potential sources:**

- LHC machine-induced, Thermal neutrons, Neutrinos

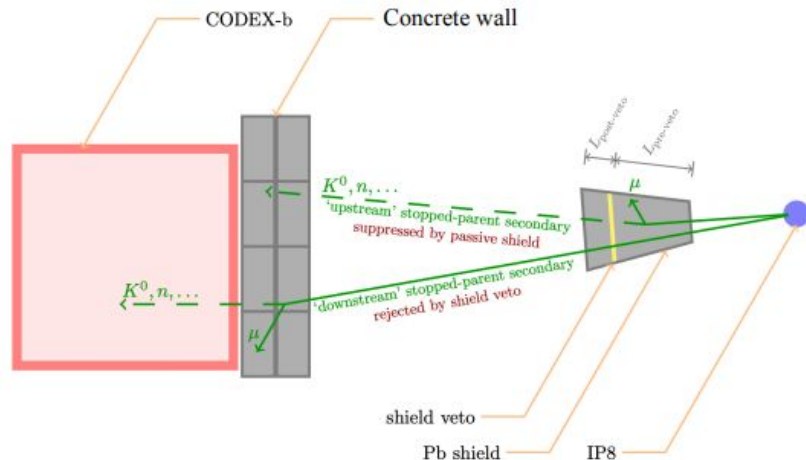

- **Detailed bkg simulation:**

- [arXiv:1708.09395](https://arxiv.org/abs/1708.09395), [arXiv:1911.00481](https://arxiv.org/abs/1911.00481)

- **Bkg levels reduced to $< \mathcal{O}$ (1 event) in 300 fb^{-1} with shields + active/topological vetoes**

- Shield + 3.2m concrete wall crucial to achieve 0 backgrounds

- Measured backgrounds in D1 area in 2018:

- [arXiv:1912.03846](https://arxiv.org/abs/1912.03846)

- FLUKA campaign from CERN Radiation Protection validated Pythia simulation

LLP Mass Determination

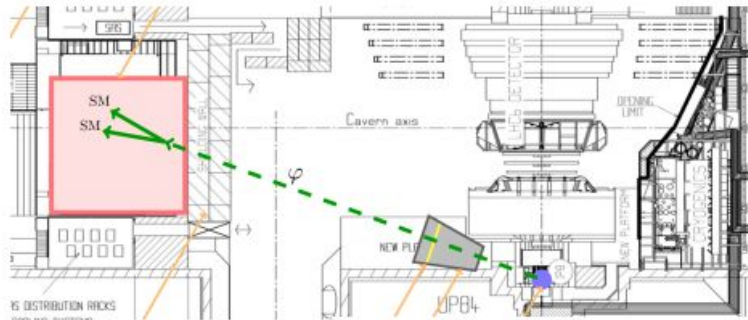

- **Design decisions** made in order to look for **GeV-scale LLPs**:

- produced in LHC collisions at LHCb,
- travel some distance, and then
- decay within the CODEX-b tracking volume

- **Crucial that the displaced vertex is well-reconstructed** in CODEX-b

- CODEX-b should also be able to **measure the LLP velocity, boost, and mass**

- Assuming a production mechanism

- **Boost distribution provides good discrimination between LLP masses and lifetimes**

**Reco LLP boost
for $h \rightarrow \gamma_d \gamma_d$**

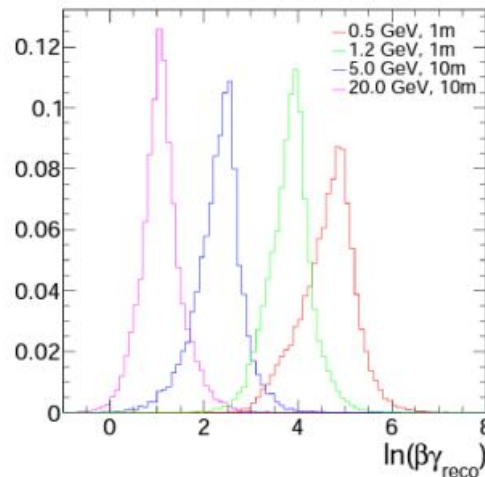

Same RPC design as BIS78 ATLAS upgrade project:

- 1mm gas gap
- Matrix of polycarbonate spacers 1cm diameter; 7cm spacing
- 1.2mm HPL, graphite-coated electrodes
- Sandwich between insulated, orthogonal strip panels (~ 25 mm pitch)
- Panels glued to insulating FOREX material
- Faraday cage case: low noise and shield FE

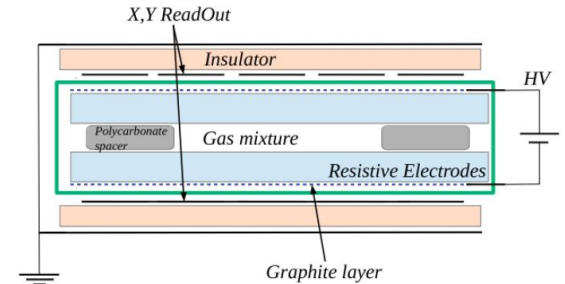

Background studies

Main LHC experiments will efficiently probe 'heavy' ($m \gtrsim 10$ GeV) LLPs, but **backgrounds become impossible** for lighter states.

Comprehensive LHC search for LLPs requires **new, special purpose, shielded detectors**

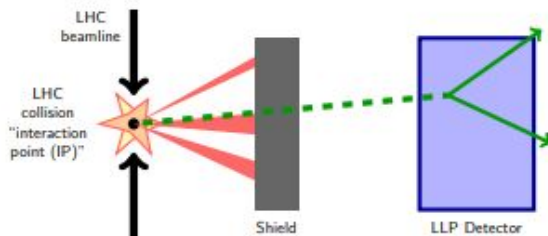

Background-free environment: searches beyond LHC main experiments' capability

Transverse detectors are needed to probe heavy mediators (including the Higgs)

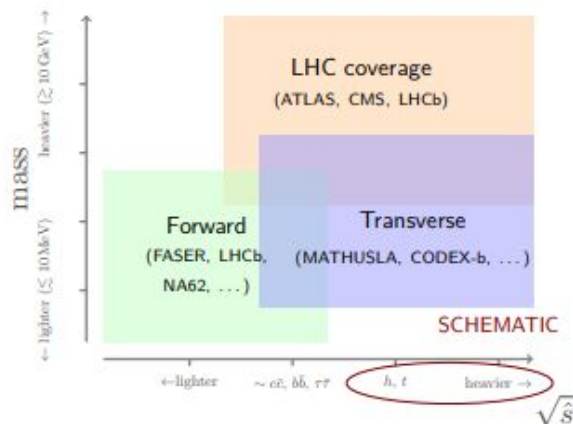

Background studies

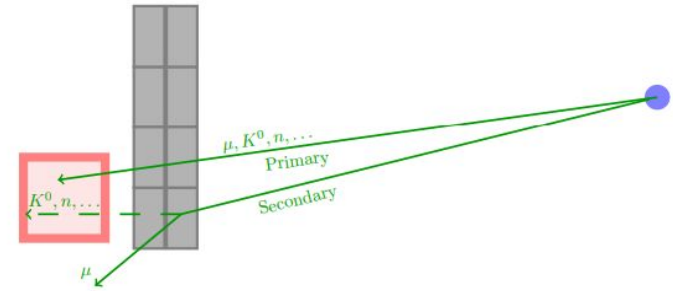

- Fluxes of SM LLPs from IP over $\log(E_{\text{kin}})$ with Pythia + G4 for shield response.
- Measure fluxes of **primary plus secondary** backgrounds versus **simulation**.
- Generate data-driven background sim framework → **optimize shielding design**.

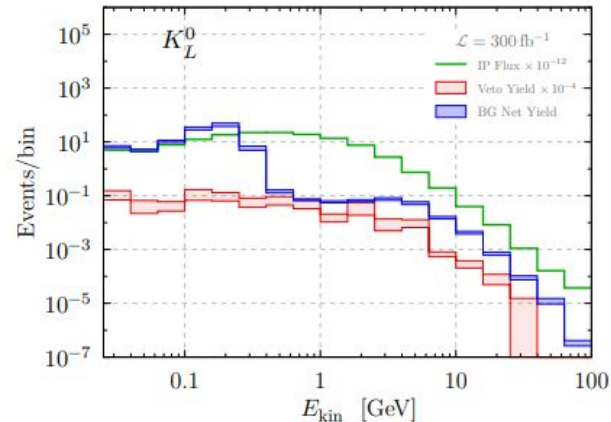
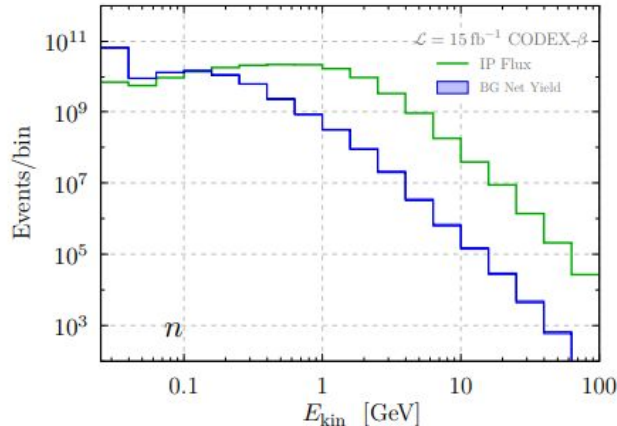

Multitrack production from LLPs

Tracks	Total	K_L^0 contribution
1	$(3.9 \pm 0.1) \times 10^8$	$(2.9 \pm 0.1) \times 10^8$
2	$(4.1 \pm 0.1) \times 10^7$	$(3.7 \pm 0.1) \times 10^7$
3	$(6 \pm 1) \times 10^5$	$(2.9 \pm 0.4) \times 10^5$
4+	$(9 \pm 2) \times 10^4$	$(7 \pm 2) \times 10^4$

- **Example:** χudd interaction, $\chi \rightarrow 4h$ decay
(Motivated by baryogenesis scenario)

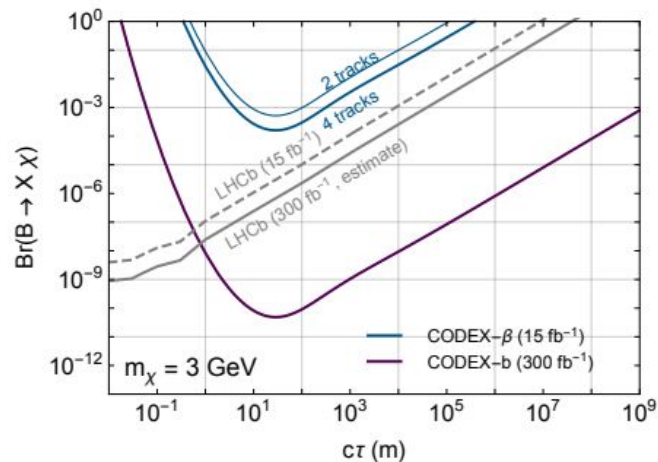

Can conduct a trial NP analysis with CODEX- β

K_S0 lifetime measurement

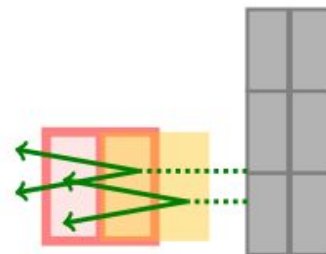
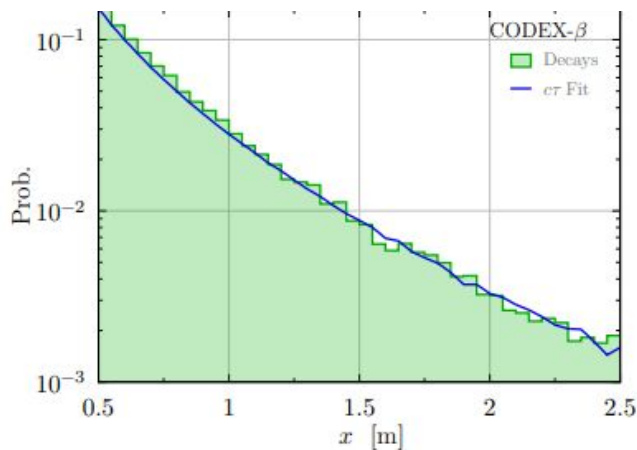

Toy CODEX-β example: (K_S0 lifetime measurement)

- Azimov dataset of 10⁶ events (i.e. ~ 10% efficiency) binned with 5 cm resolution
- Vertexing 0.5 ≤ x ≤ 2.5 m from UXA wall (assumes vertexing in 'detector shadow')
- Toy χ^2 fit: Recover $c\tau = 0.030^{+0.003}_{-0.007}$ cf. $c\tau = 0.02686(1)$ m.

Goals and roadmap from reconstruction

Three main goals:

1. Trigger on interesting events → **no need to be reconstructed** (anomaly detection),
2. Provide a **set of tracks for physics analysis**,
3. Provide estimates of **efficiencies and resolutions on physics quantities**.

Goals 1 and 2 can be decoupled if we use different techniques, but **dependent on memory storage** – can we afford to store triggered events offline.

Personpower much needed to help with reconstruction efforts!

CODEX-b locations from LHCb perspective

Would the active veto/Pb shield block access to VELO/RICH1/UT/Magnet?

On D1-D3 counting rooms:

- D1/D2 housed event-filter farm and control system during Run 1 and 2.
- System will be relocated to UX85 during Upgrade Ib/II.
- Refurbishment of D1/D2 during LS3, D3 will be used for electronics rack.

Wishful thinking: can we come up with an idea to prevent the need to refurbish D1/D2?

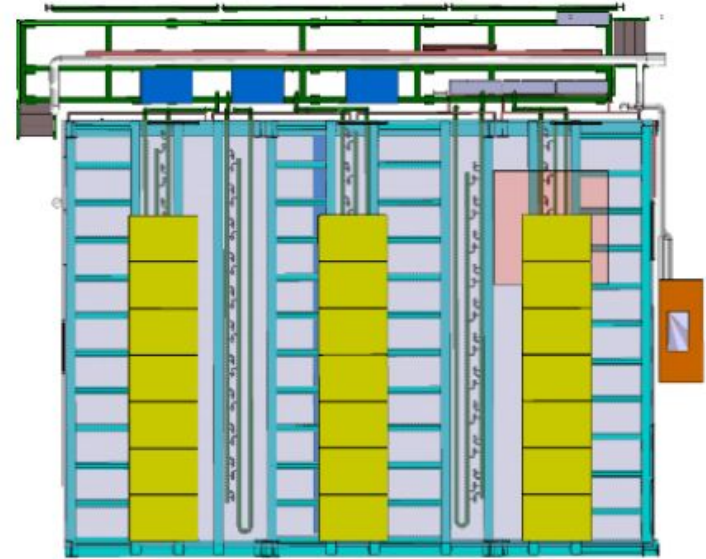

Draft layout for D1 refurbishment in LS3.

CODEX-b locations from LHCb perspective

On UGC1 gallery:

- Unused but in an unfinished state. Not planned to be used by LHCb.
- **Require civil engineering, ventilation, safety systems, access (cost estimate).**
- **Not accessible when beam is on.**

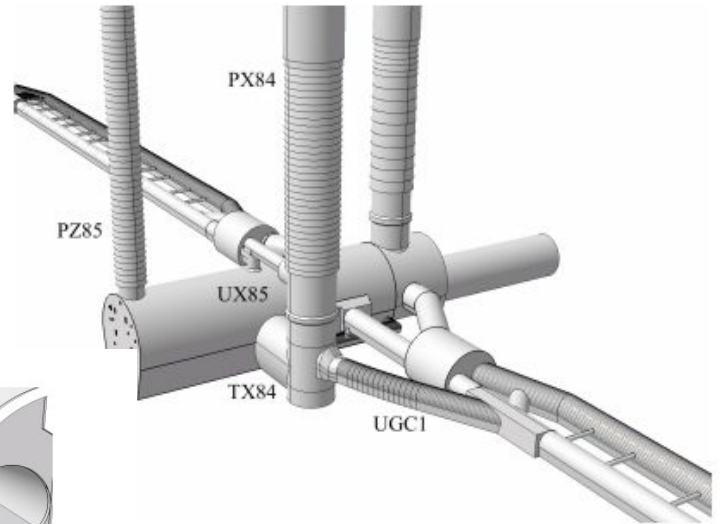
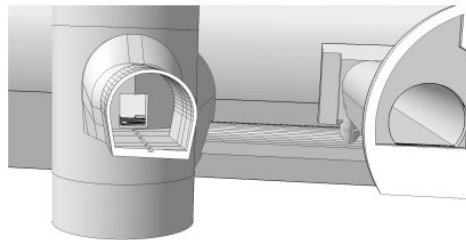

CODEX-b locations from LHCb perspective

Between shielding wall and counting rooms:

- Position of shielding wall **must be compatible with handling of detector parts**, e.g. transport between PX84 shaft and UX85B cavern through TX84 gallery.
- **Moving the concrete blocks would create a gap that needs to be covered.**
- **Metallic structure, supporting services and cable/trays have to stay.**

Must leave some passing way, for instance, underneath the detector!

CODEX-b locations from LHCb perspective

Dismantling Delphi: likely to be unviable in terms of safety and operation.

Using Delphi's visitor platform:

- 11 x 3 m surface area with possible height limitations.
- Metallic structure needs to be reinforced.
- Might also be needed in LHCb for Upgrade II (e.g. cooling plants).

CODEX-b locations from LHCb perspective

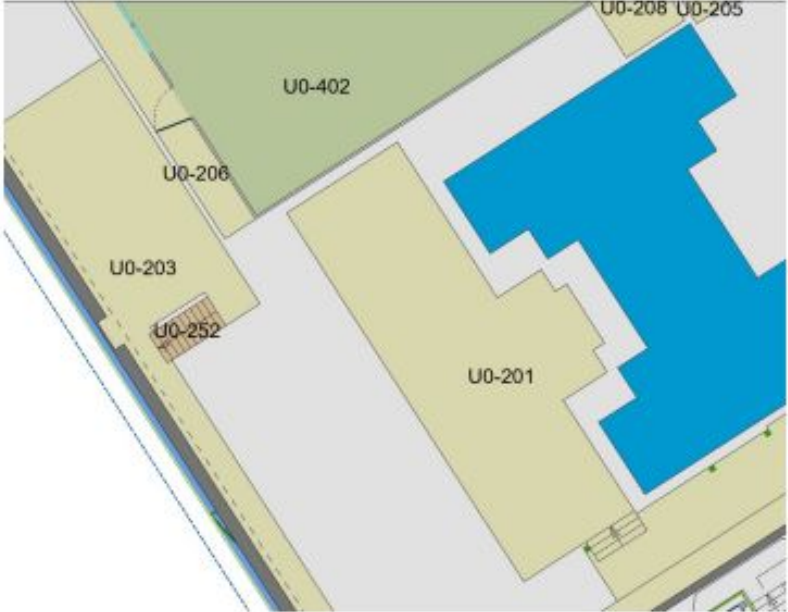
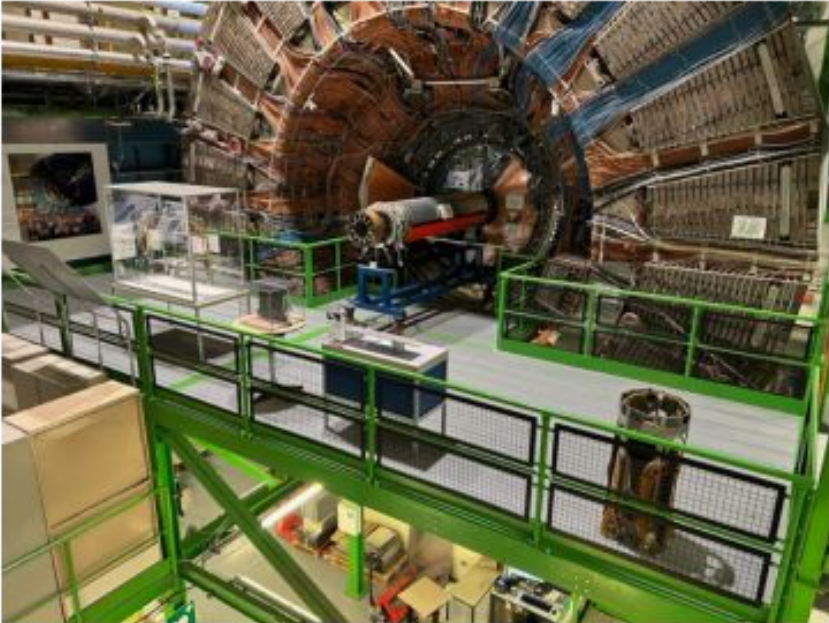

CODEX-b locations from LHCb perspective

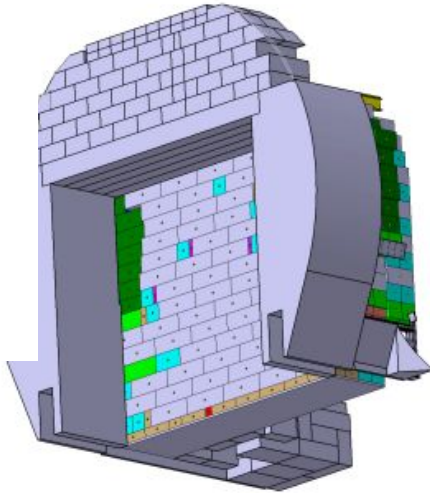
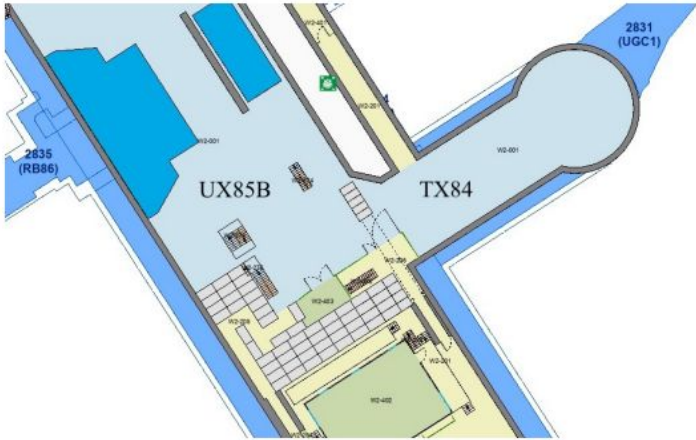

View from UX85A.

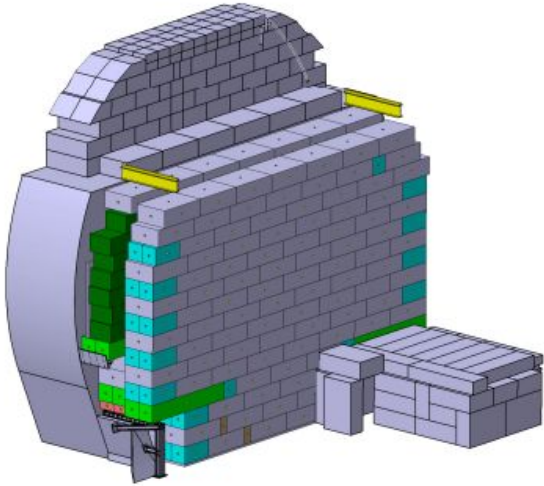

View from UX85B.

Assembling and testing the RPCs

Target: assemble **14 panels**, with a RPC triplet each → **42 RPC singlets**.

1. Assemble and test RPC singlets individually.
2. Assemble three RPC singlets, and then one **RPC triplet**: insert three singlets into a frame → each triplet weighs **150 kg**.
3. Test the RPC triplet.

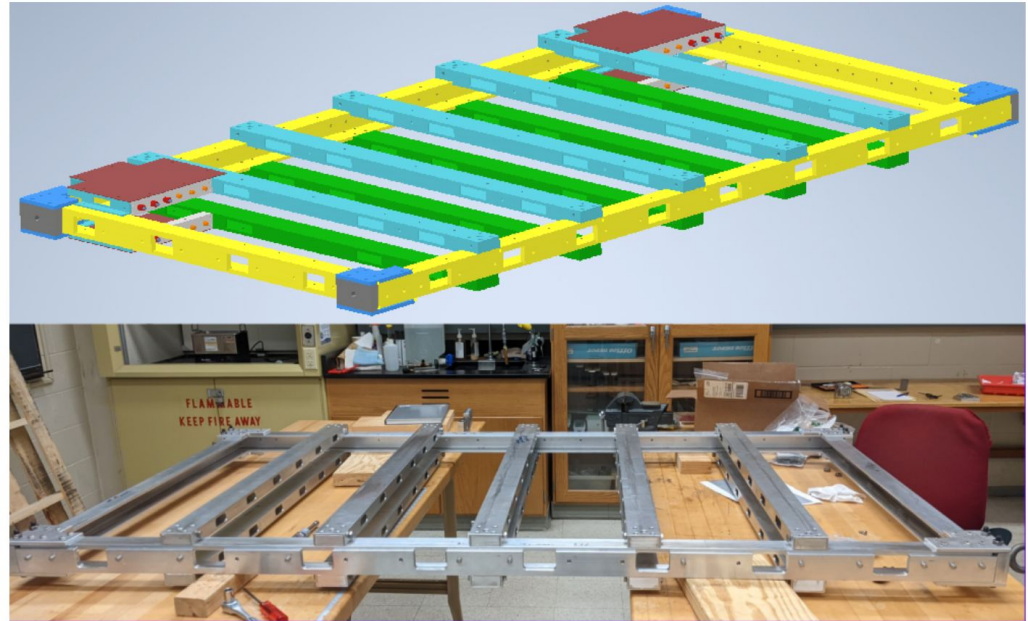

Preparing the D1 barracks

D1 barracks are empty now, power supply available.

Working now on:

- **Providing a gas line for RPCs,**
- Preparing the safety procedure for working in D1.
- Transport from B904 to P8 (300 kg/frame), use of PZ lift.

Gas system:

- **Mixer + recirculation system ordered and underway.** Extensive discussions with CERN gas group. 64% R134a, 30% CO₂, 5% isobutane, 1% SF₆.
- **GHG emissions not scalable for CODEX-b → R&D in search for an ecomixture.**

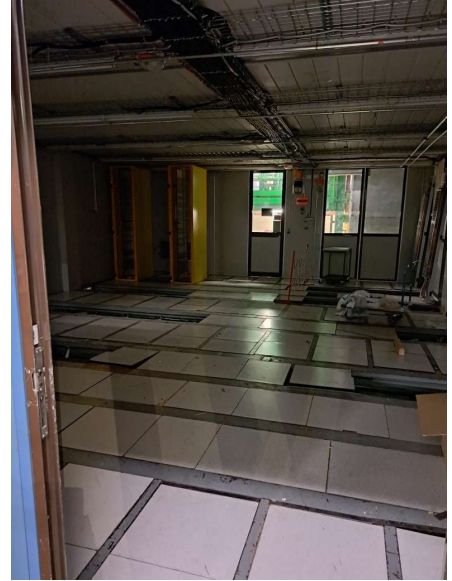

DAQ, readout and integration with LHCb

- RPCs readout by DCTs (Data Collection & Transmission).
- **DCT readout design being finalized by ATLAS experts.**
- Development with LHCb experts on slow control (LV, HV, Gas, monitoring).
- **Control, communication, and synchronisation with LHCb are challenging:**
 - Firmware for RPCs to be developed to make the output LHCb compatible.
 - **Need for FPGA expertise to make DCT readout LHCb-compatible.**



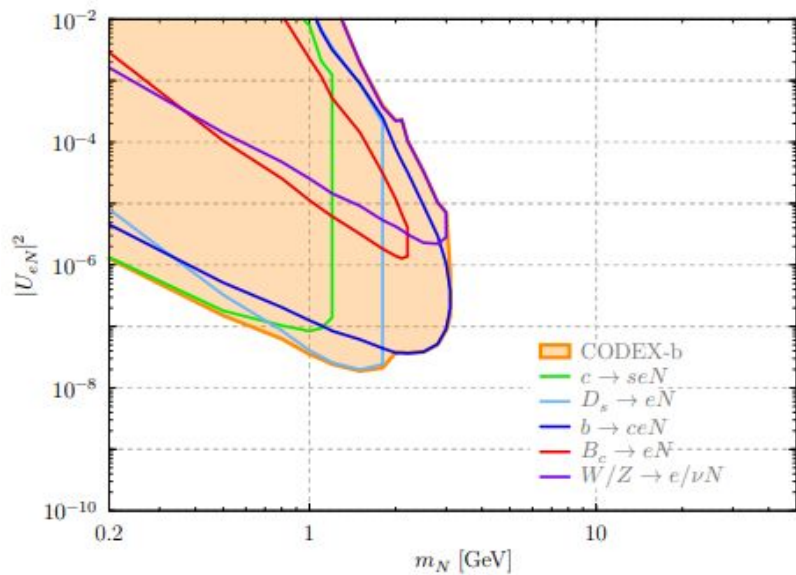

(a) $U_{eN} \gg U_{\mu N}, U_{\tau N}$ (Channels)

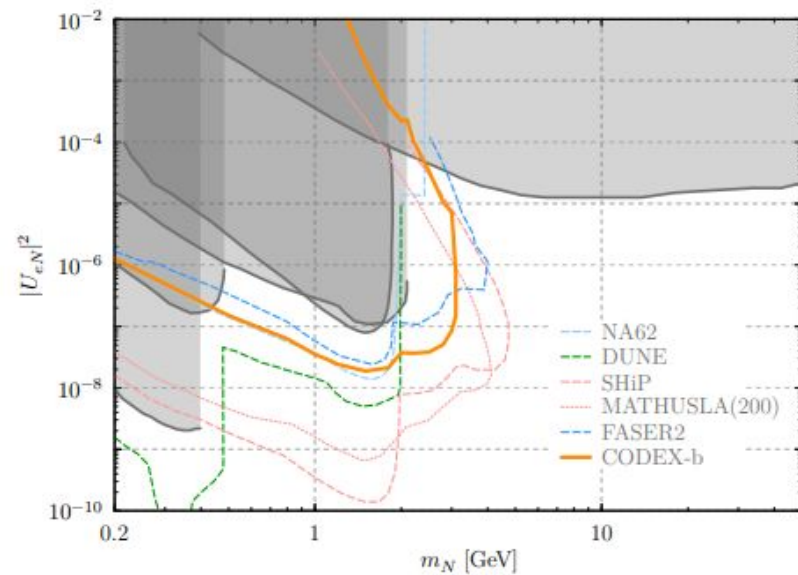

(b) $U_{eN} \gg U_{\mu N}, U_{\tau N}$ (Combined)

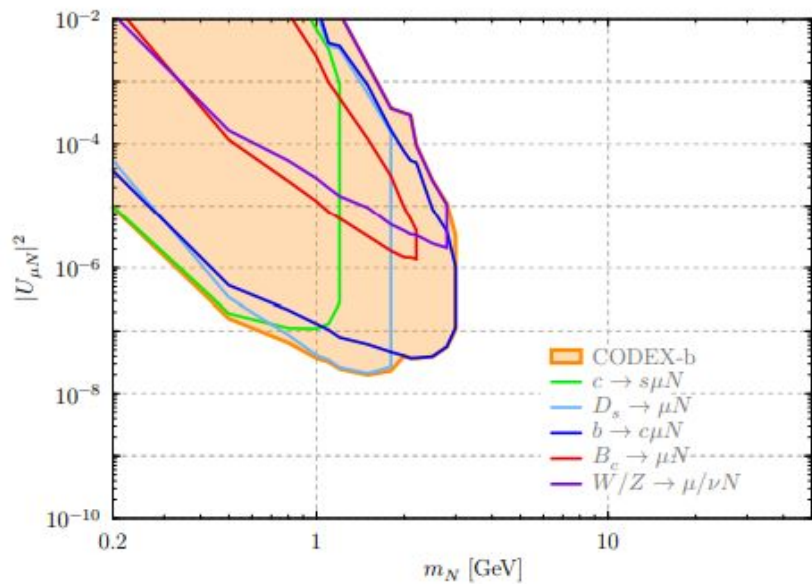

(c) $U_{\mu N} \gg U_{eN}, U_{\tau N}$ (Channels)

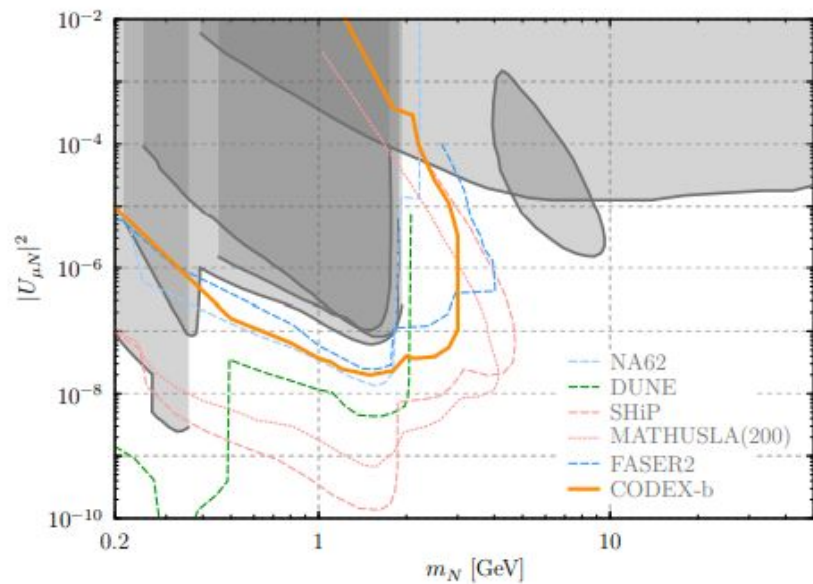

(d) $U_{\mu N} \gg U_{eN}, U_{\tau N}$ (Combined)

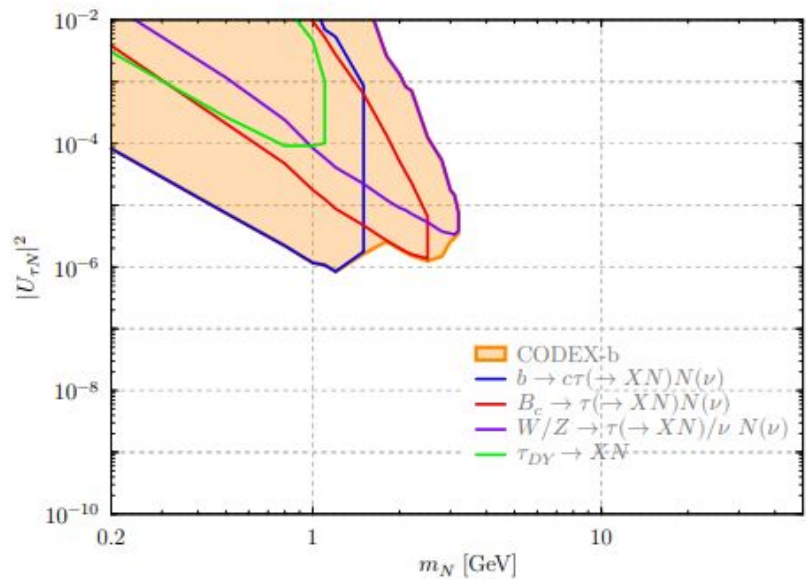

(e) $U_{\tau N} \gg U_{eN}, U_{\mu N}$ (Channels)

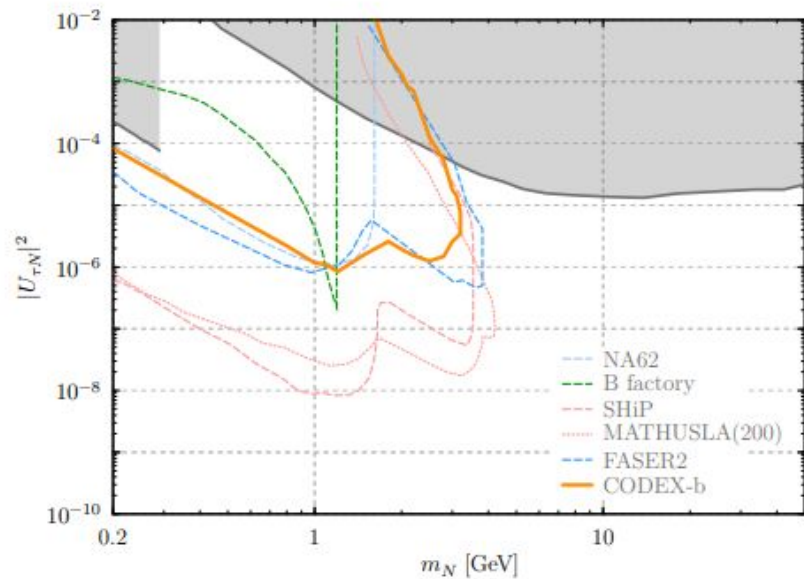

(f) $U_{\tau N} \gg U_{eN}, U_{\mu N}$ (Combined)

Experiments and timescales

LHCb-U1 (2022-2032): 50 fb⁻¹ (A)

LHCb-U2 (2035-2041): 300 fb⁻¹

ANUBIS (2035-2041): 3 ab⁻¹ (ATLAS)

CODEX-b (2035-2041): 300 fb⁻¹

SHiP (2031-2046): 6x10²⁰ pot (A)

NA64-e: 2022-2025 (Run3) (A)

NA64-mu: 2029-2032 (Run4) (Pilot run approved)

LDMX (SLAC): approved, start run in 2028 (A)

A = approved.

LHCb U1

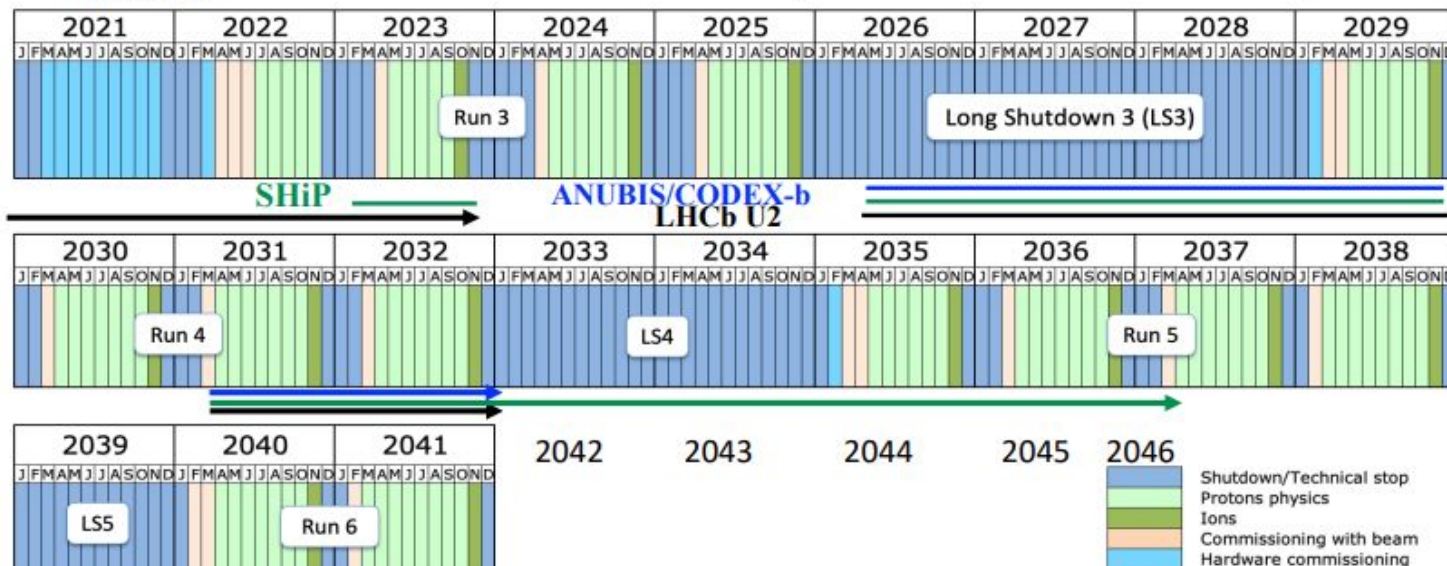

Last update: April 2023

ALP mediator with fermion couplings

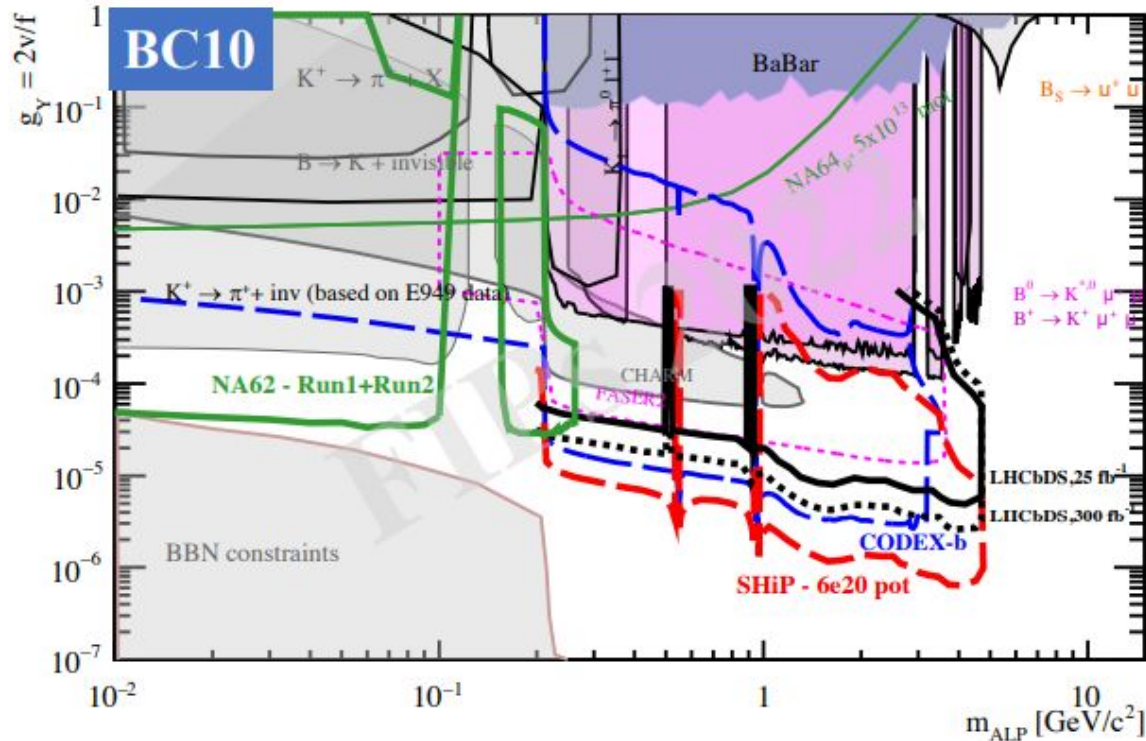

Worldwide leading project < 10 years: LHCb-U1 with 25 fb^{-1}

Worldwide leading projects > 10 years: LHCb-U1/U2 & CODEX-b, SHiP

5.1.2 – Ongoing Projects: ATLAS, CMS, LHCb, and HL-LHC

The LHCb experiment, despite smaller luminosity and detector coverage, has a unique design that covers particles produced at small angles to the beam which allows it to be competitive with the general purpose detectors for some new particle searches. **This is particularly true for Higgs decays into long-lived particles, where LHCb can leverage its advanced tracking and vertexing capabilities along with real-time data processing.** Its upgrade for HL-LHC will allow for significant increase in instantaneous luminosity and sensitivity to the hidden sectors (Recommendation 3c).

5.1.3 – New Initiative: A Portfolio of Agile Projects to Search for Direct Evidence of New Particles

Another strategy to look for long-lived particles at colliders is to construct auxiliary experiments that are placed far away from the primary collision points. **Proposed auxiliary experiments like CODEX-b and MATHUSLA can extend the sensitivity to BSM particle lifetimes in Higgs decays by several orders of magnitude.** Experiments at the proposed Forward Physics Facility at CERN like FASER2 and FORMOSA would be sensitive to the hidden sectors through the Vector and Heavy Neutral Lepton portals. At Fermilab, PIP-II is expected to make many more protons than needed for DUNE, and we anticipate proposals for experiments using the excess protons. These experiments should compete in the portfolio for agile projects (see Recommendation 3a and Section 6.2).

Figure 2 – Construction in Various Budget Scenarios

Index: N: No Y: Yes R&D: Recommend R&D but no funding for project C: Conditional yes based on review P: Primary S: Secondary
 Delayed: Recommend construction but delayed to the next decade
 # Can be considered as part of ASTAE with reduced scope

Scenarios	US Construction Cost >\$3B			Science Drivers							
	Less	Baseline	More	Neutrinos	Higgs Boson	Dark Matter	CP Violation	Exotic Evidence	Dark Energy	Quantum Gravity	Astronomy & Astrophysics
on-shore Higgs factory	N	N	N		P	S			P	P	
\$1-3B											
off-shore Higgs factory	Delayed	Y	Y		P	S			P	P	
ACE-BR	R&D	R&D	C		P					P	P
\$400-1000M											
CMB-S4	Y	Y	Y		S	S	P				P
Spec-S5	R&D	R&D	Y		S	S	P				P
\$100-400M											
IceCube-Gen2	Y	Y	Y		P	S					P
G3 Dark Matter 1	Y	Y	Y		S		P				
DUNE FD3	Y	Y	Y		P				S	S	S
test facilities & demonstrator	C	C	C			P	P			P	P
ACE-MIRT	R&D	Y	Y		P						
DUNE FD4	R&D	R&D	Y		P				S	S	S
G3 Dark Matter 2	N	N	Y		S		P				
Mu2e-II	R&D	R&D	R&D								P
srEDM	N	N	N								P
\$60-100M											
SURF Expansion	N	Y	Y		P		P				
DUNE MCND	N	Y	Y		P				S	S	
MATHUSLA #	N	N	N				P			P	
FPF #	N	N	N		P		P			P	

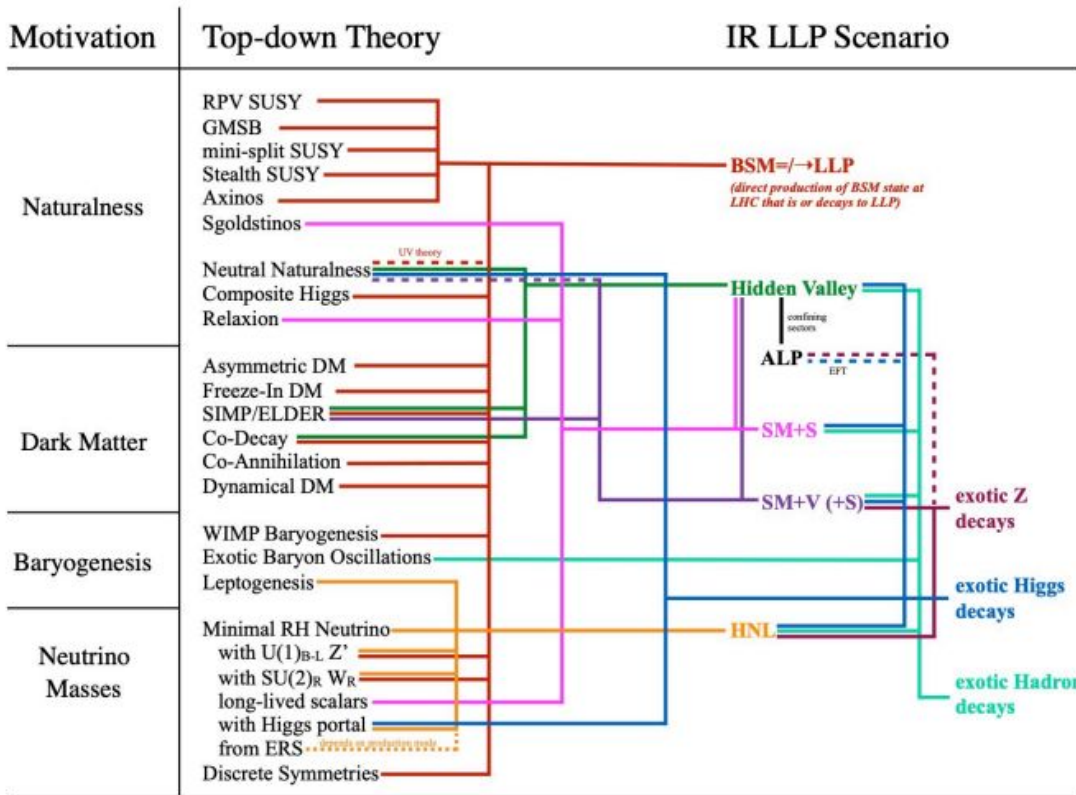

Mathusla physics case
arxiv:1806.07396

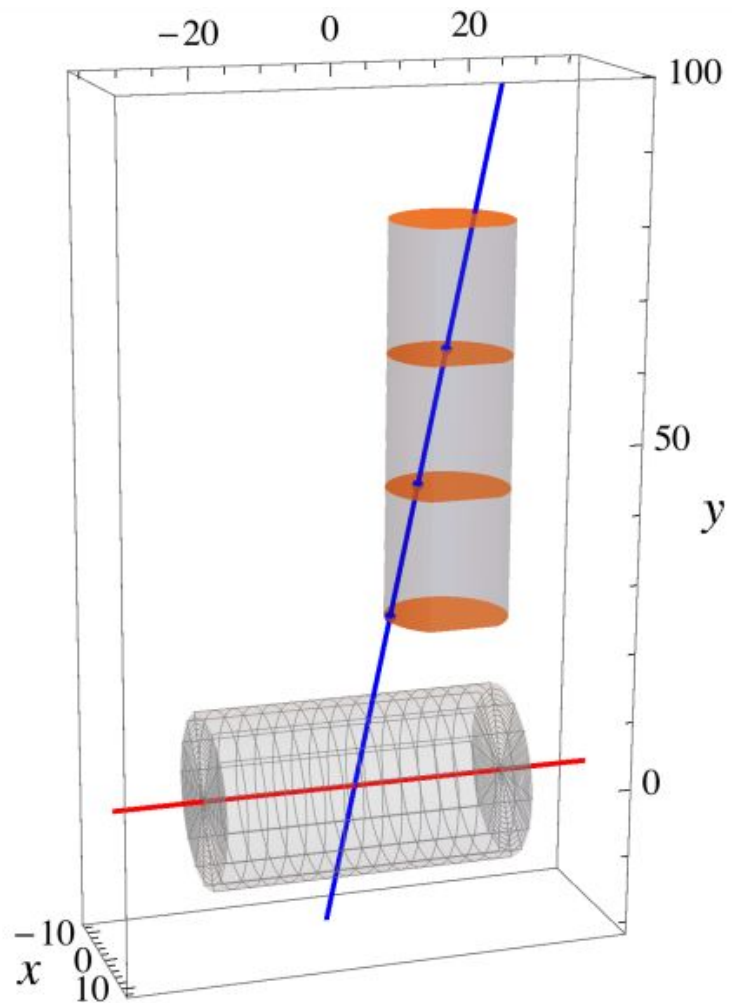
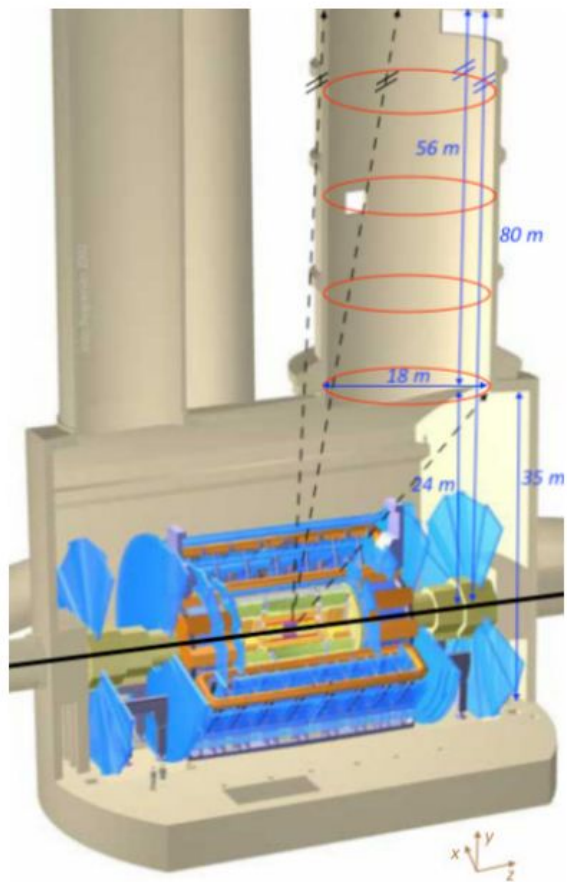

◆ Relies the new proposed SPS Beam Dump Facility (BDF), would provide huge statistics (5 years of BDF, 2×10^{20} protons on target!)

- ➔ Search for Hidden Particles (SHiP) designed for discovery and measurement of super-weakly interacting new particles
- ➔ Ultra-low background environment. First part of SHiP: muons and hadron absorbers
- ➔ A long vacuum chamber of about 50m allows long-lived particles to disintegrate
- ➔ Detect leptons and mesons, a muon detector and an electromagnetic calorimeter are placed downstream

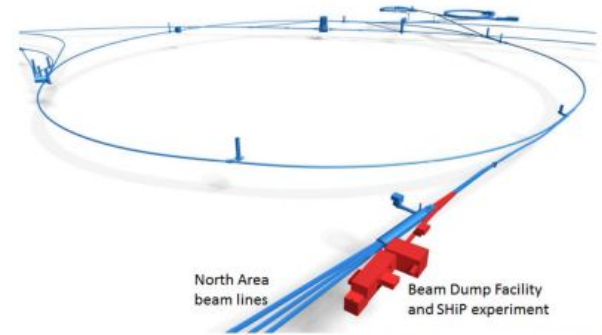

[INST 14 (2019) no.03, P03025]

[CERN-PBC-REPORT-2018-001]

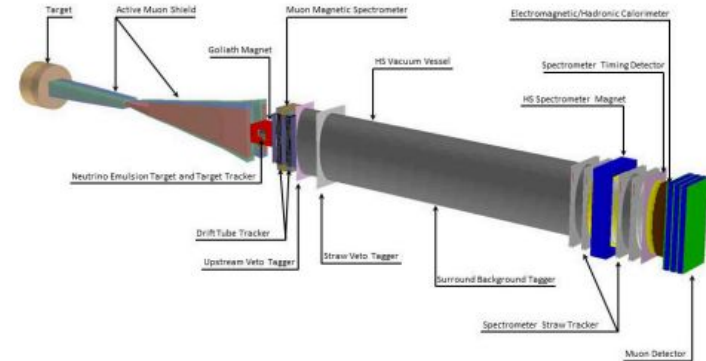

◆ ForwArd Search ExpeRiment (FASER) new small LLP experiment in an old LEP injector tunnel (TI12)

- Most advanced proposal: FASER experiment (phase-I) has been approved March 2019
- Designed to collect 150 fb^{-1} from 2021-2023
- FASERv, potential extension to detect (for the first time) LHC neutrinos!
- LHC forward physics facility: idea to extend the idea of FASER to build more forward experiments (SND@LHC, FORMOSA...)

